

LITTLE BLASTER™

LARRY HESS AND ASSOCIATES, INC.

BLAST-IT-ALL®

P.O. BOX 1615

SALISBURY, NC 28145

WWW.BLAST-IT-ALL.COM

LITTLE BLASTER™ OYSTER SHELL WITH DUST COLLECTOR

MANUAL NUMBER: 562

TABLE OF CONTENTS

<i>PAGE</i>	<i>FIGURE</i>	
1	-	<i>SET-UP INSTRUCTIONS OYSTER SHELL</i>
2	-	<i>OPERATING INSTRUCTIONS</i>
3	-	<i>OPERATING & SERVICE DUST COLLECTOR</i>
4	-	<i>GENERAL MAINTENANCE</i>
5	1	<i>STANDARD CABINET PARTS</i>
6	2	<i>AIR CONTROL, SET-UP</i>
7	3	<i>AIR CONTROL, PARTS</i>
8	4	<i>MACHINE LIGHTING, PARTS</i>
9	5	<i>BLAST GUN, PARTS</i>
10	6	<i>DUST COLLECTOR, PARTS</i>
11	7	<i>ELECTRICAL DIAGRAM</i>
12	8	<i>OYSTER SHELL MODEL</i>
13	-	<i>MACHINE WARRANTY</i>
		<i>WARRANTY REGISTRATION FORM</i>

WARNING

DO NOT USE SAND. SAND WILL CAUSE SILICA DUST, WHICH IS THE CAUSE OF SILICOSIS DISEASE, A CONDITION OF MASSIVE FIBROSIS OF THE LUNGS. THIS STATEMENT INDICATES POTENTIAL PERSONNEL HAZARD.

**FAILURE TO COMPLY WITH THESE INSTRUCTIONS
MAY RESULT IN PERSONAL INJURY.**

WEBSITE CONCERNING SILICOSIS:

<http://www.osha.gov/Silica/IT69D 1.html>

LITTLE-BLASTER™

SET-UP INSTRUCTIONS OYSTER SHELL WITH CARTRIDGE TYPE DUST COLLECTORS

***** READ BEFORE OPERATING EQUIPMENT *****

1. Remove all shipping protection
Check for any concealed shipping damage, if discovered, report damage to your freight carrier immediately.
2. Lift the top section JUST ENOUGH TO remove the hardware and rear leg support brackets from inside the machine.
3. Mount cabinet rear leg brackets to the back of the rear legs using holes provided. (SEE FIGURE 9 PAGE 13)
4. Remove the lag bolts from each leg and remove the machine from the pallet.
5. Lift the top section and allow it to rest on the cam support arm in the open position.
6. Install Air Controls
"See Page 6 - Figure 2"
7. Remove the Dust Collector from the skid. Remove the two shipping brackets and install Cartridge Dust Collector:
(SEE FIGURE 8 ITEM 2 PAGE 12)
8. Plug electrical cord from side of dust collector into plug from light box.

(READ OPERATION AND SERVICING OF DUST COLLECTOR)
9. Connect your air supply line to machine air inlet on left rear leg, we recommend using 1/2" I.D. Hose or Pipe minimum supply line. (Again, make sure your air supply line is free from oil and moisture). (If not, install a good moisture separator). **Part #: 16-815 (DO NOT USE ANY QUICK DISCONNECT COUPLINGS)**
10. Connect electrical cord from light box to grounded electrical source, 120-volt/60 cycle, single phase. A 20 AMP breaker or fuse should be used. **MAKE SURE MACHINE HAS PROPER GROUND**
11. Charge blast machine with abrasive. Pour media into cabinet through one of the doors and fill to bottom of screen in sump of cabinet. **DO NOT FILL ABOVE SCREEN.**

Packaged with machine are bolts, washers, nuts and putty tape.

Apply putty tape to large hole on the right side dust collector support plate, press to make a firm bond to cabinet and squeeze together at seam. Align

the 4 holes and install bolts, washers, and nuts. Tighten bolts and nuts securely.

the 4 holes and install bolts, washers, and nuts. Tighten bolts and nuts securely.

the 4 holes and install bolts, washers, and nuts. Tighten bolts and nuts securely.

the 4 holes and install bolts, washers, and nuts. Tighten bolts and nuts securely.

the 4 holes and install bolts, washers, and nuts. Tighten bolts and nuts securely.

*****CAUTION*** ***CAUTION*****
Do not use sandblasting sand. This will cause silica dust, which is the cause of silicosis disease, a condition of massive fibrosis of the lungs!

LITTLE-BLASTER™ OYSTER SHELL

OPERATING INSTRUCTIONS

***** READ BEFORE OPERATING EQUIPMENT *****

1. Preparing parts for Blasting:

All parts to be processed must be free of oil, grease, and moisture. Make sure parts are dry before putting into cabinet for cleaning.

2. Air Pressure:

Set air pressure at 80 PSI. Most parts for blasting cleaning should be blasted at 80 PSI. Designate parts to be processed, start at lower pressure and work up the PSI scale to obtain desired finish.

*****WARNING*****

DO NOT CONNECT TO HIGH PRESSURE BOTTLE GAS, RUPTURE AND EXPLOSION CAN OCCUR.

3. Gun Angle and Distance:

Direct blast at part with an approximate (45-60) degree angle with ricochet toward the back side of cabinet. Do not hold at 90 degree to part being processed. This will cause the blast media to bounce back into the blast stream and slow blasting action. Also 90-degree angle will cause excessive wear on gun and viewing window. Hold gun approximately 6 inches from part being cleaned.

*****WARNING*****

GUN MUST ALWAYS BE POINTED AWAY FROM THE OPERATOR AND TOWARD ITEM BEING PROCESSED. NEVER BLAST WITH ANY OF THE CABINET DOORS OPEN. WHILE LOADING AND UNLOADING, NO ONE SHOULD BE AT THE OPERATOR STATION AT FRONT OF THE BLAST CABINET.

4. Media:

Media should be good quality and dry. Damp media will cause the media not to flow and will clog abrasive flow. NEVER USE SAND. See **** CAUTION ****, below. If you are having a problem selecting media for a specified job, contact your distributor for their recommendations.

**** CAUTION ****

**** CAUTION ****

DO NOT USE SAND BLASTING SAND. THIS WILL CAUSE SILICA DUST WHICH IS THE CAUSE OF SILICOSIS DISEASE, A CONDITION OF MASSIVE FIBROSIS OF THE LUNGS.

LITTLE-BLASTER™ OYSTER SHELL
OPERATING AND SERVICING
CARTRIDGE DUST COLLECTOR

***** READ BEFORE OPERATING EQUIPMENT *****

After installing Dust Collector, it is very important to follow the next steps. This will assure your machine will blast satisfactorily and have good visibility in blast chamber. (Refer to FIGURE 6 – PAGE 10)

1. Remove RED nuts securing the motor housing and cartridge holder to dust collector body. (Item 1) Discard these nuts, they are not used.
2. Loosen elastic nuts on back corners. (Item #2) Loosen until the elastic is to the bottom on the bolt thread. This will allow the motor housing and cartridge holder to rest securely on the gasket seal.
3. To clean cartridge: Turn Dust Collector switch off. Grasp lift handle (Item 11), and raise up and down vigorously allowing the top housing to thump on the body lip (#5). Do this repeatedly, until loose dust on the cartridge (#2) falls off into the dust sump. This should be done every 30 minutes of blasting, or each time before use. It is a good idea occasionally to remove motor housing and with 10-15 PSI of airline pressure from air nozzle, blow the cartridge pleats clean.

***** WARNING *****

Use low air pressure ONLY. High air pressure will blow holes in the cartridge.

4. After thumping the cartridge, the drain cap (#10), should be removed and the dust emptied from dust collector sump, (#1), into a box, bag or container, for ease of disposing.

THIS DUST SHOULD NOT BE RESUED

If dust is detected coming from the vent holes (#9), this is an indication the cartridge is loose or leaking. Either tighten cartridge or replace. If not serviced this will cause the motor to fail and bearings to seize.

5. Maintained properly, you will enjoy the performance of this reliable type dust collector.

LITTLE-BLASTER™ OYSTER SHELL MAINTENANCE INSTRUCTIONS

*** READ BEFORE OPERATING EQUIPMENT ***

1. **Blasting Gun:**

After 10 - 12 hours of blasting time the air orifice and nozzle should be checked. If the nozzle shows wear, rotate 1/4 turn to prevent uneven wear. If this is not checked, it could result in destruction of nozzle and damage to the gun housing. If wear is detected on the orifice tip, replace.

2. **Caking of Media:**

A. Media caking is caused by moisture in compressed air supply or oily and greasy parts. If this is not corrected, media will not flow and will clog gun. Check air supply. If water or moisture is present, install a good moisture trap. If oily or greasy parts are being blast treated, you should first degrease and dry parts.

B. If blast gun should occasionally clog, place thumb over nozzle (hold tight) and push foot valve down 3 to 4 seconds. This will cause the system to back blast through the gun and media hose, and clear the media hose.

3. **Gun Air Pressure Drop:**

Set air regulator at 80 PSI on air gauge. Push foot valve and if gauge reading should drop, check the air supply pipe or hose. A restriction in the supply line such as reducers or quick couplers will cause pressure drop. Also, if the blast cabinet is too far from the air compressor, a pressure drop can occur. We recommend 1/2" - 1" I.D. air supply line. The bigger the better.

4. **Poor Visibility - Excessive Dust:**

- A.** Cabinet Air inlet blocked, check for blockage.
- B.** Dust collector sump full and needs emptied.
- C.** Cartridge contaminated. Clean by pushing up and down.
(Refer to page 3 - #3).
- D.** Media breakdown - replace media and clean dust collector.

5. **Poor Media Flow:**

- A.** Wet or damp media caused from moisture or oil in compressed air line.
- B.** Use dry air or install a moisture filter.
- C.** Replace media and clean media sump and hose.
- D.** Media level should be below media screen.
- E.** Hole in media hose from wear, replace hose assembly.

****CAUTION**

****CAUTION****

**DO NOT OPEN ANY OF THE DOORS
WHILE MACHINE IS IN OPERATION**

****CAUTION****

****CAUTION****

**DO NOT USE SAND BLASTING SAND.
THIS WILL CAUSE SILICA DUST
WHICH IS THE CAUSE OF SILICOSIS
DISEASE, A CONDITION OF MASSIVE
FIBROSIS OF THE LUNGS.**

LITTLE-BLASTER™

OYSTER SHELL PARTS

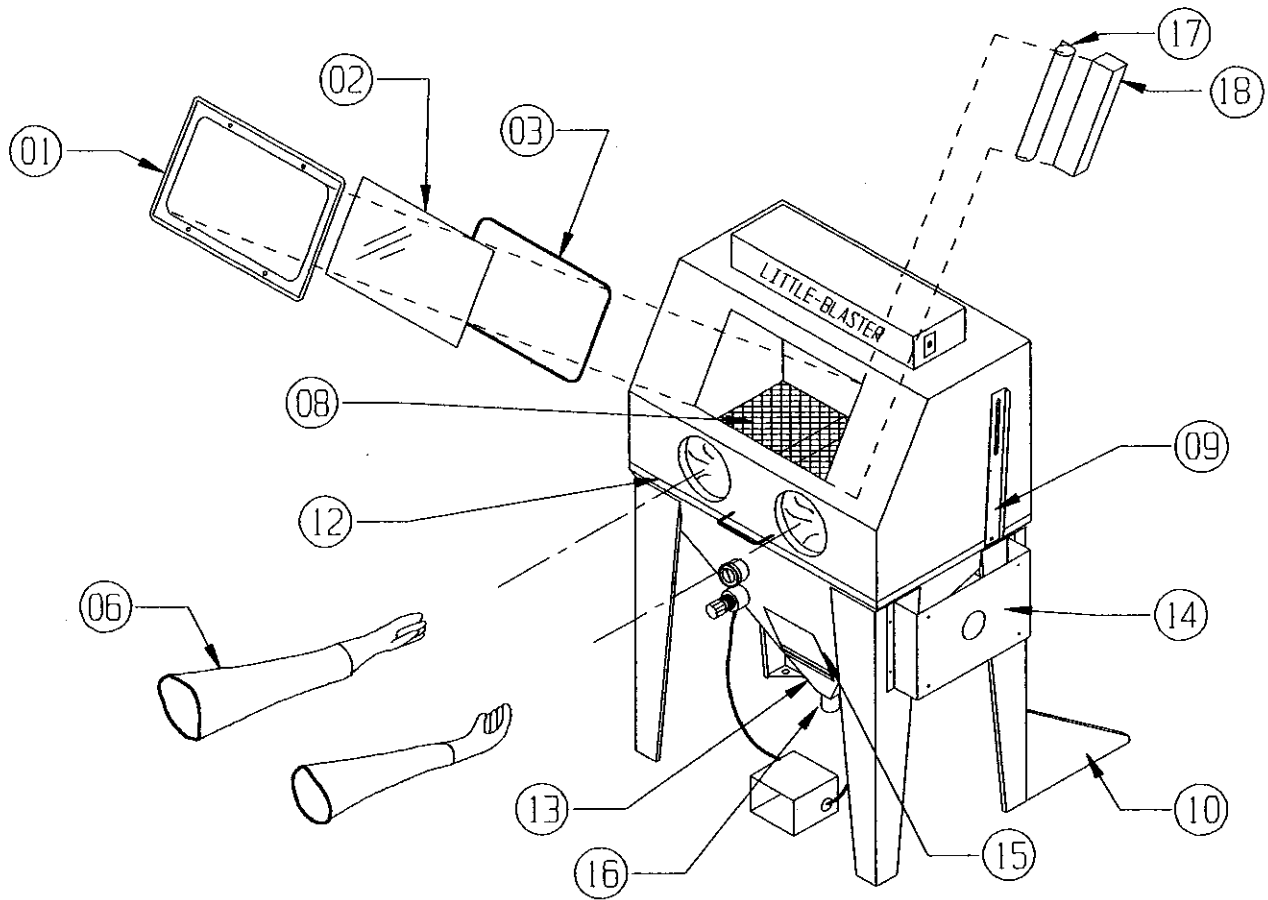

ITEM NO.	PART NO.	DESCRIPTION
1	23-053	WINDOW FRAME
2	23-050	WINDOW, VIEWING
3	24-054-64	WINDOW GASKET
4	-----	-----
5	-----	-----
6A	22-111	GLOVE, SNAP-IN (LEFT ONLY)
6B	22-112	GLOVE, SNAP-IN (RIGHT ONLY)
7	-----	-----
8	10-152-42	GRATE (LB 42240S)
9	D112-23	TOP SLIDE LATCH
10	D112-25	LEG SUPPORT
11	15-720	DOOR CAM RUBBER GRIP
12	24-054-132	GASKET
13	10-050-42	SUMP SCREEN (LB 42240S)
14	D112-24	DUST COLLECTOR OR RECLAIMER MOUNT
15	24-055	CLEAN OUT DOOR GASKET
16	20-200	MEDIA VALVE
17	011191	MYLAR GLASS PROTECTOR
18	011190	MYLAR HOLDER

Figure 1

LITTLE-BLASTER™

SET-UP INSTRUCTIONS

LITTLE-BLASTER AIR CONTROLS INSTALLATION

*** READ BEFORE OPERATING EQUIPMENT ***

1. Remove box from machine with Blast Gun and Air Controls.
2. Connect regulator to bracket with lock ring.
3. Connect inlet air hose to left rear leg of machine.
4. Run air hose through machine sump grommet and connect to gun handle.
5. Connect media hose to pick-up tube.

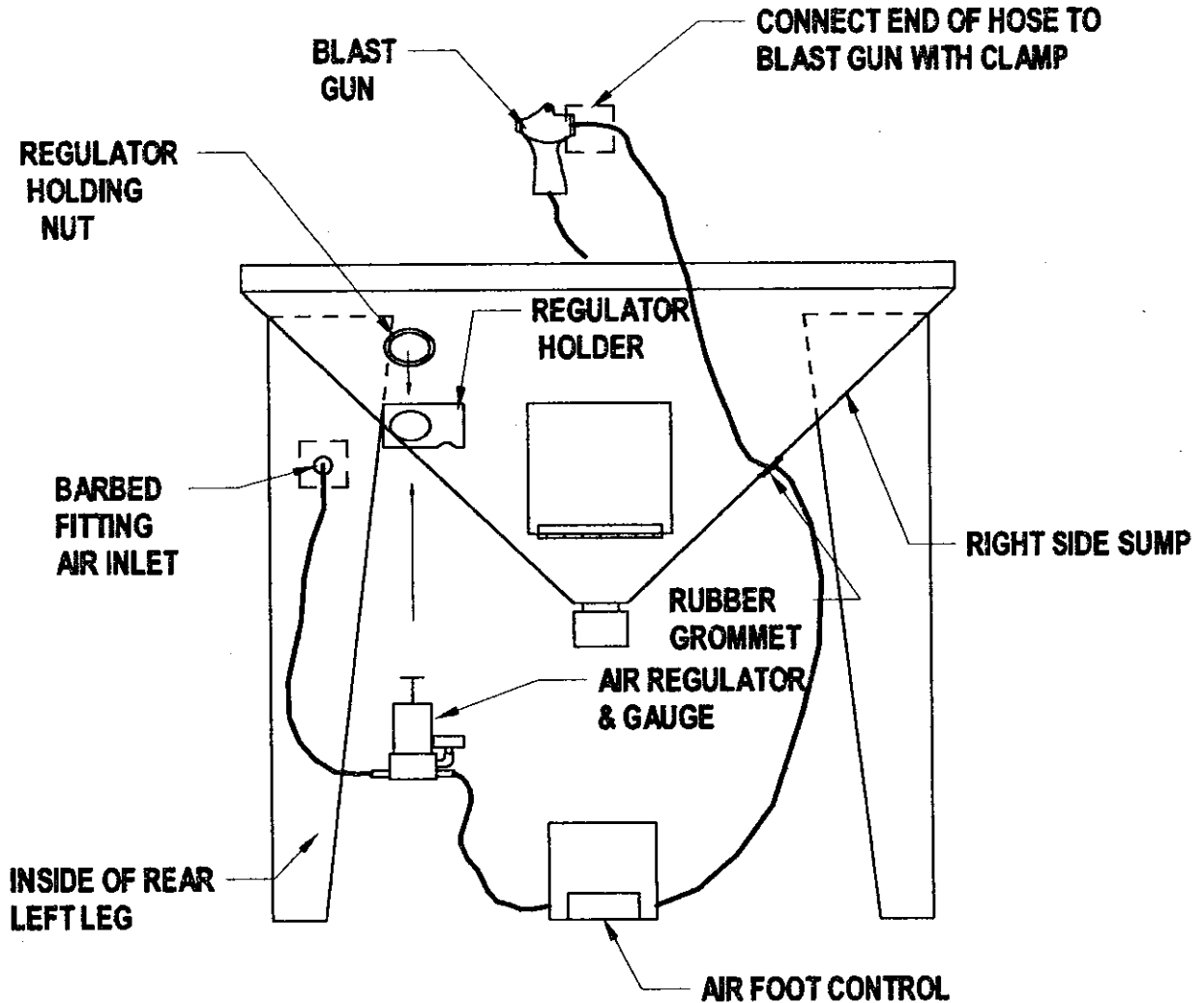
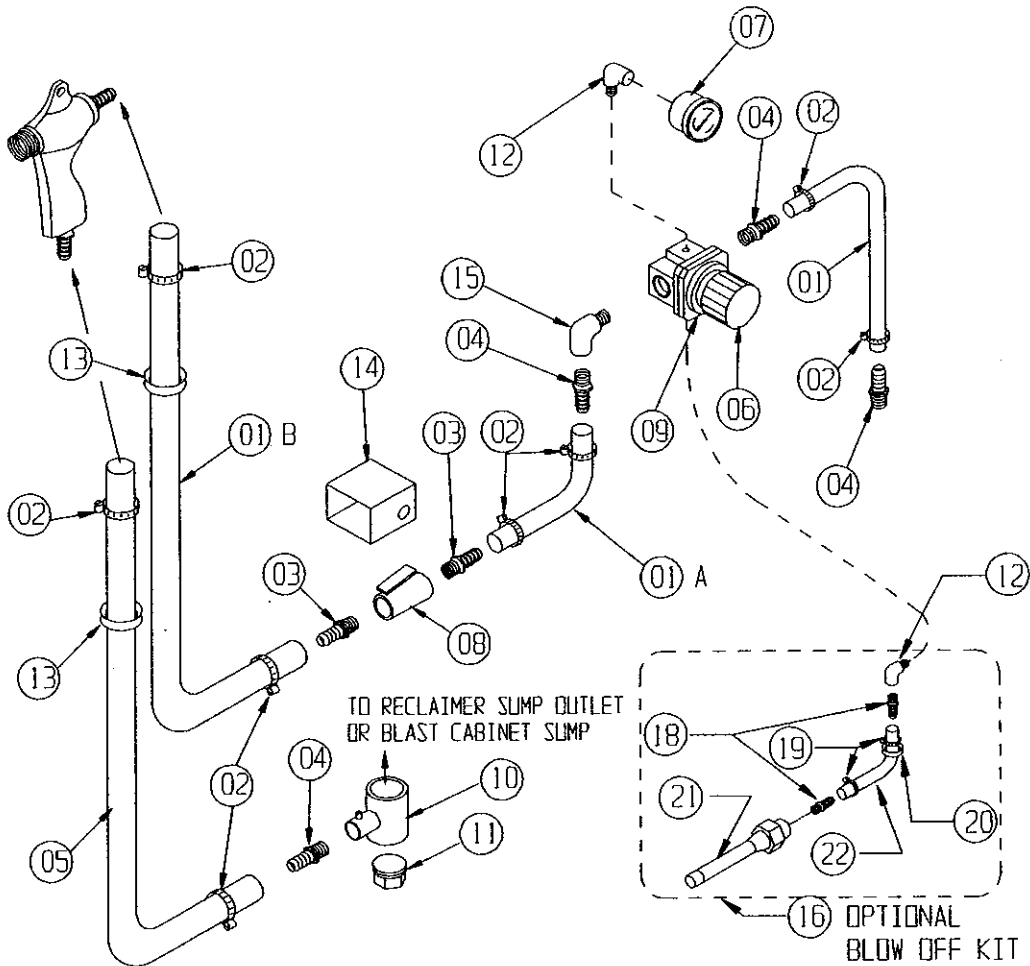

Figure 2

MACHINE AIR CONTROLS



ITEM NO.	PART NO.	DESCRIPTION
1	18-076-2	HOSE, AIRLINE (2 FT.)
1A	18-076-3	HOSE, AIRLINE (3 FT.)
1B	18-076-7	HOSE, AIRLINE (7 FT.)
2	21-032	CLAMP, HOSE
3	14-302	FITTING, 1/2" HOSE x 3/8" MPT
4	14-301	FITTING, 1/2" HOSE x 1/2" MPT
5	18-084-6	HOSE, MEDIA LINE (6 FT.)
6	16-965	REGULATOR, AIR 1/2"
7	16-820	GAUGE, AIR
8	16-835	VALVE, AIR FOOT CONTROL ONLY
9	16-965LR	REGULATOR LOCK RING
10	20-200	MEDIA VALVE
11	20-201	PLUG (MEDIA VALVE)
12	002301	1/4" STREET ELL
13	24-050	GROMMET, HOSE
14	16-836	HOUSING, FOOT CONTROL ONLY (NO VALVE)
15	14-372	1/2" STREET ELL
16	009059	OPTIONAL BLOW OFF KIT
17		-----
18	14-313	FITTING, 1/4 x 1/4 NPT
19	010412	CLAMP, 1/4" AIR HOSE
20	24-052	GROMMET
21	16-822	BLOW OFF NOZZLE
22	000738-6	HOSE, 1/4" AIR x 6' LONG

Figure 3

LITTLE-BLASTER™

LIGHT BOX

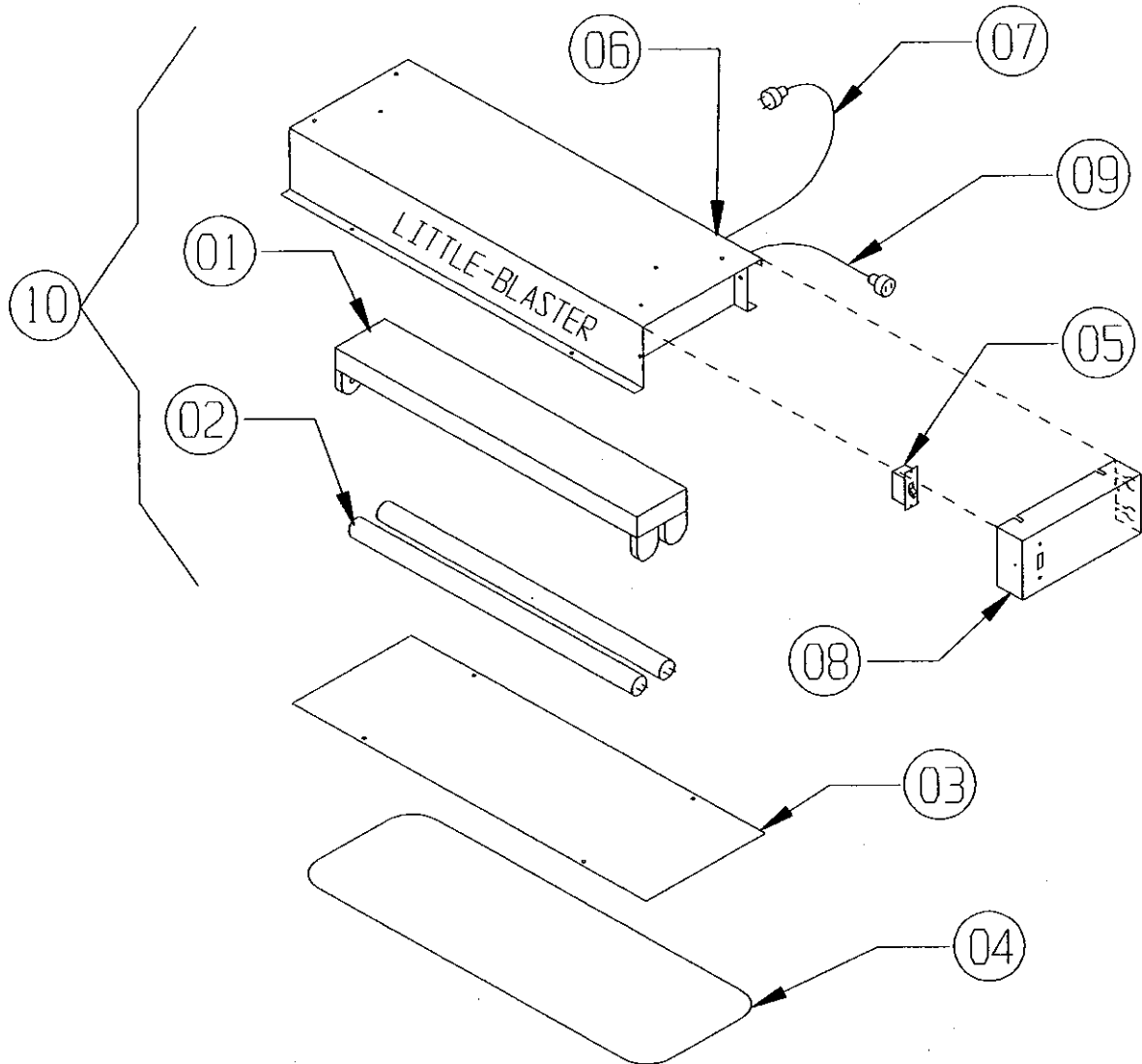

ITEM NO.	PART NO.	DESCRIPTION
1	13-533	FLUORESCENT FIXTURE, (NO TUBES)
2	13-534	24" FLUORESCENT TUBE
3	010216	PROTECTOR, LIGHT
4	24-054-64	WINDOW GASKET, 64" IN LENGTH
5	13-655	SWITCH
6	13-605	HEYCO CONNECTOR
7	13-550	POWER CORD, 3 WIRE
8	B198-2	SWITCH MOUNTING PLATE
9	010172F	CORD WITH FEMALE PLUG
10	010800 LBLTBX	COMPLETE LIGHT BOX (EXCEPT 3 & 4)

Figure 4

LITTLE-BLASTER™
BLAST GUN ASSEMBLY

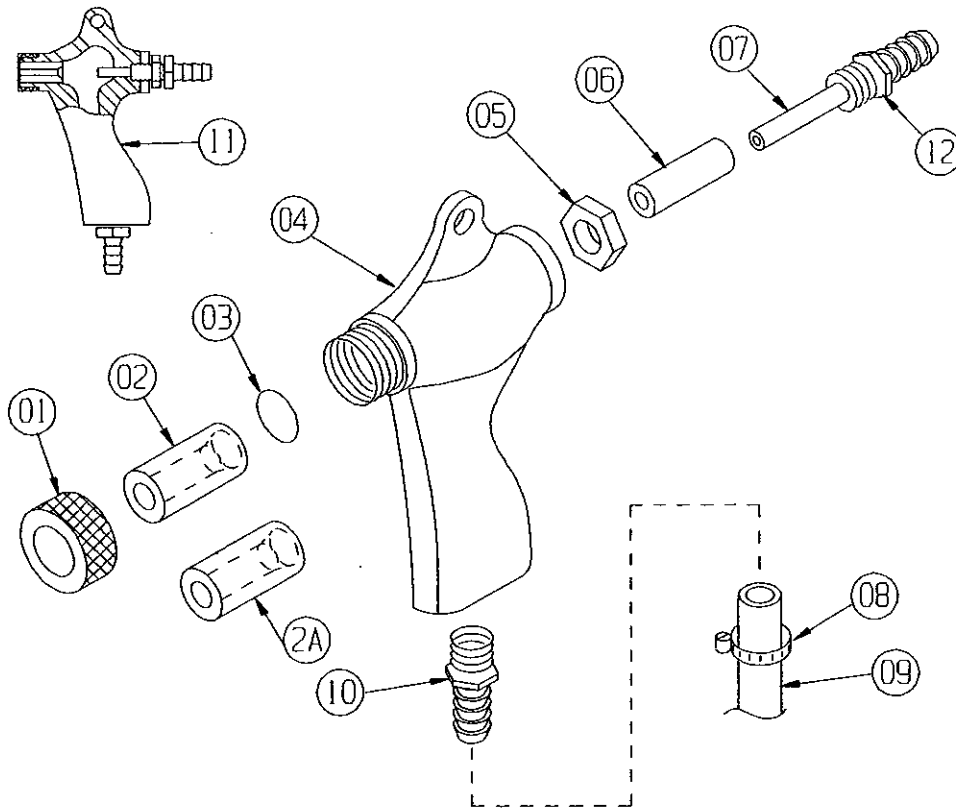

ITEM NO.	PART NO.	DESCRIPTION
1	20-054	NOZZLE NUT HOLDING
*2	20-074	NOZZLE CERAMIC, 1/4" I.D. SIZE 4
2	20-075	NOZZLE CERAMIC, 5/16" I.D. SIZE 5
2	20-076	NOZZLE CERAMIC, 3/8" I.D. SIZE 6
2A	20-084	NOZZLE CARBIDE, 1/4" I.D. SIZE 4
2A	20-085	NOZZLE CARBIDE, 5/16" I.D. SIZE 5
2A	20-086	NOZZLE CARBIDE, 3/8" I.D. SIZE 6
3	20-053	"O" RING - NOZZLE SEALING
4	20-040	GUN BODY ONLY
5	20-052	LOCKNUT, DRIFICE
6	20-063	RUBBER COVER, DRIFICE
*7	20-064	DRIFICE AIR 4/32" I.D. SIZE 4 INCLD. #6 & 7
7	20-065	DRIFICE AIR 5/32" I.D. SIZE 5 INCLD. #6 & 7
7	20-066	DRIFICE AIR 6/32" I.D. SIZE 6 INCLD. #6 & 7
8	21-032	CLAMP, HOSE
9	18-084	HOSE, MEDIA 1/2" I.D. (SPECIFY LENGTH)
10	14-302	FITTING-HOSE TO GUN 1/2" HOSE x 3/8" MPT
11	20-041	GUN, STD. COMP. W/CERAMIC NOZZLE (SPECIFY SIZE)
11	20-042	GUN, STD. COMP. W/CARBIDE NOZZLE (SPECIFY SIZE)
12	-----	GUN SIZE IS STAMPED ON AIR DRIFICE HEX
*13	20-041-4	STANDARD SUPPLIED WITH CABINET

Figure 5

CARTRIDGE DUST COLLECTOR

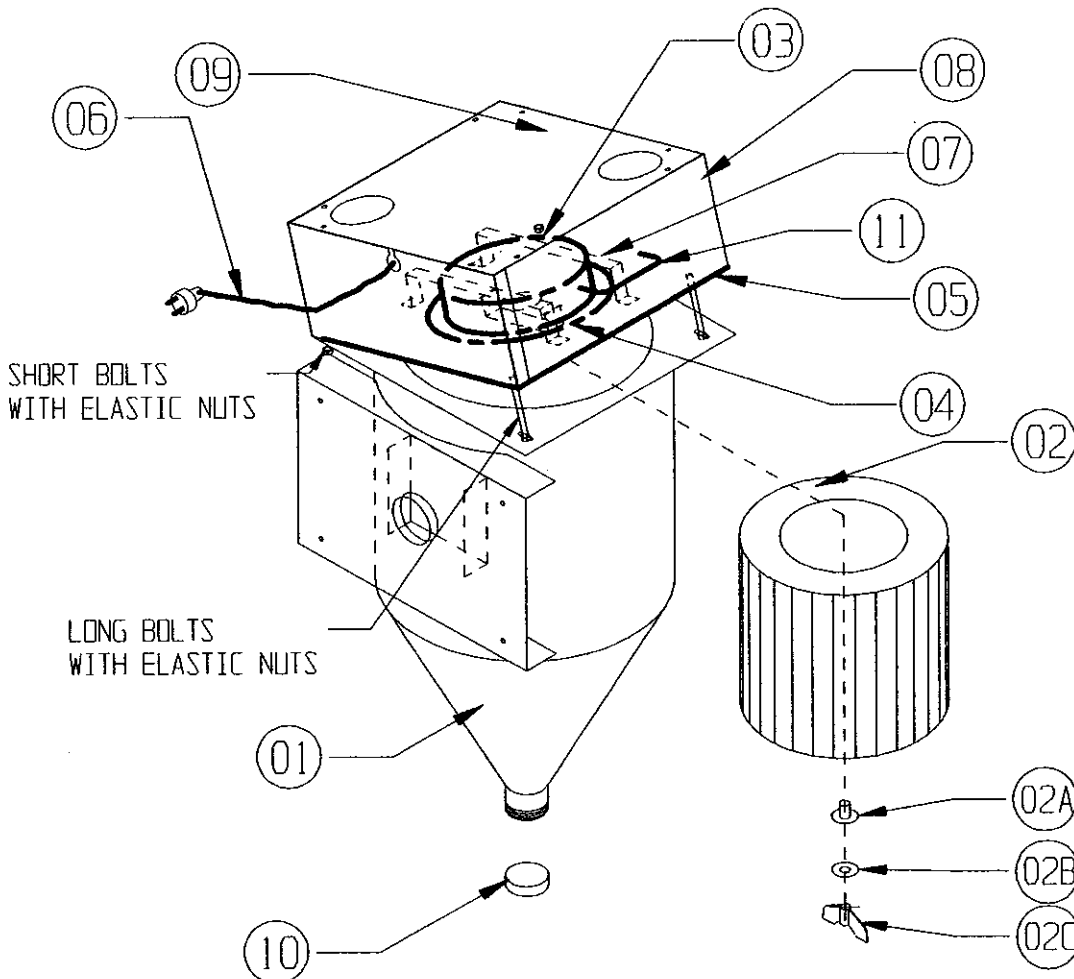

SHORT BOLTS WITH ELASTIC NUTS

LONG BOLTS WITH ELASTIC NUTS

*NOTE: ITEM (2A) RUBBER SEAL MUST BE IN PLACE TO REDUCE PREMATURE MOTOR FAILURE

ITEM NO.	PART NO.	DESCRIPTION
1	D2025	DUST COLLECTOR BODY
2	11-1524	DUST COLLECTOR CARTRIDGE (INCLUDES 2A,2B,2C)
2A	11-1524S	RUBBER SEAL
2B	30-601	1/4" WASHER
2C	30-510	1/4" WING NUT
3	13-200	MOTOR, 120V, 60/50 Hz, 6.9 AMP
4	24-056	GASKET, MOTOR SEAL
5	24-054-48	GASKET, TOP SEALING
6	010172	CORD, MALE PLUG
7	D2025-09	MOTOR BRACKETS
8	D2025-05&06	MOTOR HOUSING
9	D2025-04	COVER PLATE
10	010212	2" PIPE CAP
11	-----	LIFT HANDLE

Figure 6

LITTLE-BLASTER™

ELECTRICAL DIAGRAM

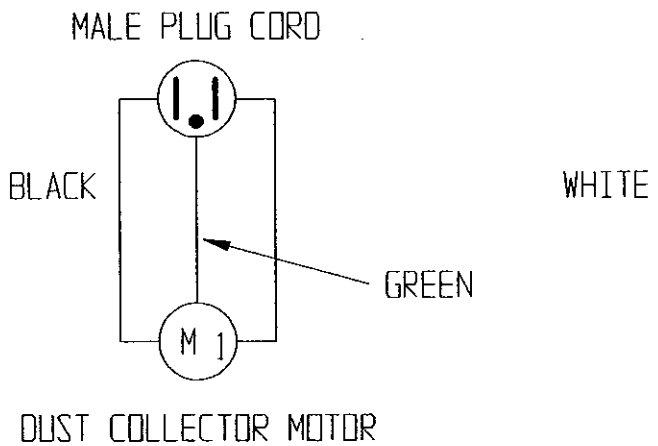
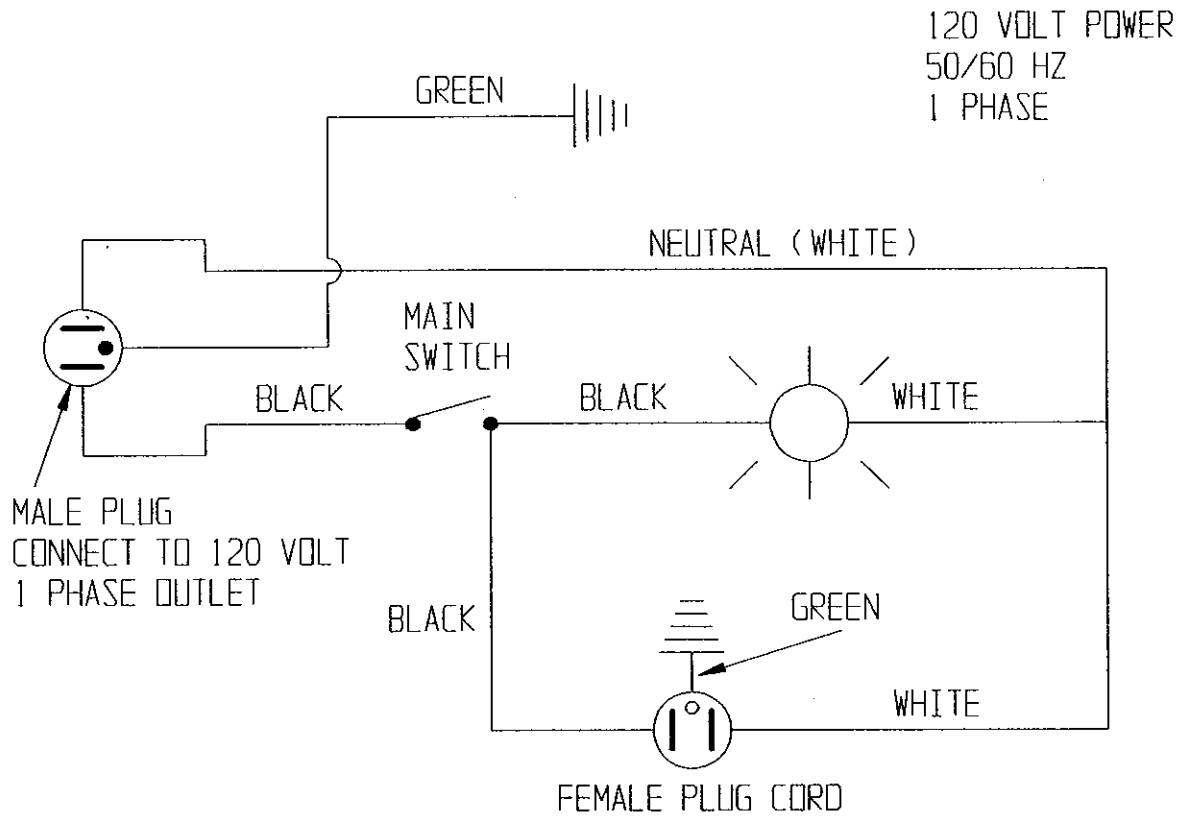

Figure 7

LITTLE-BLASTER™

SET-UP INSTRUCTIONS

OYSTER SHELL MODELS

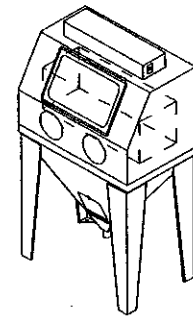
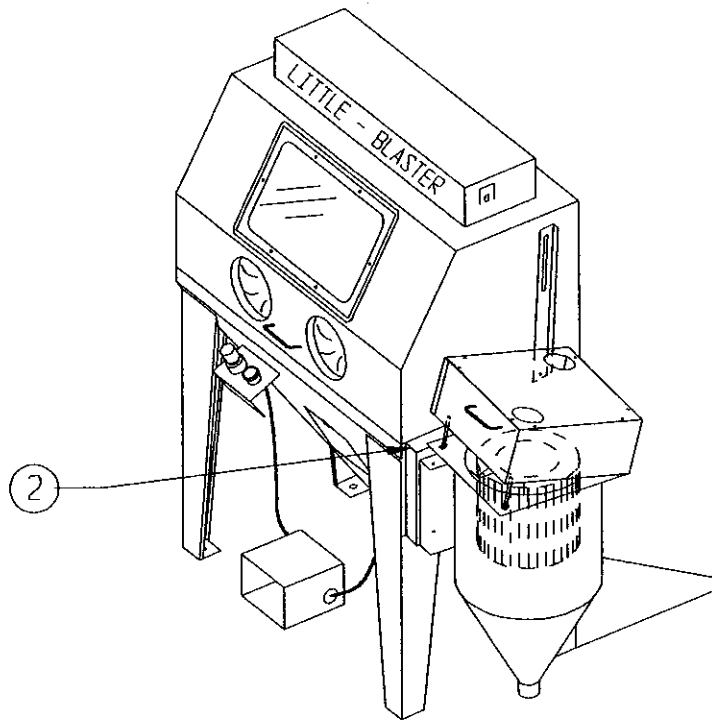

Fig. A

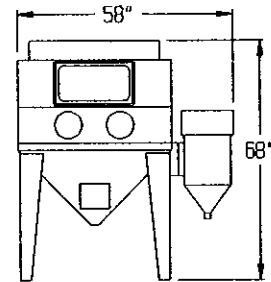

Fig. B

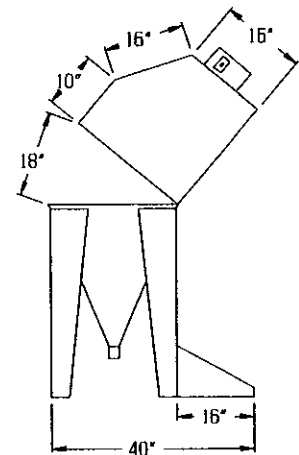

Fig. C

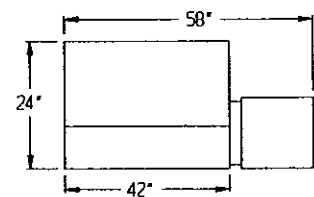

Fig. D

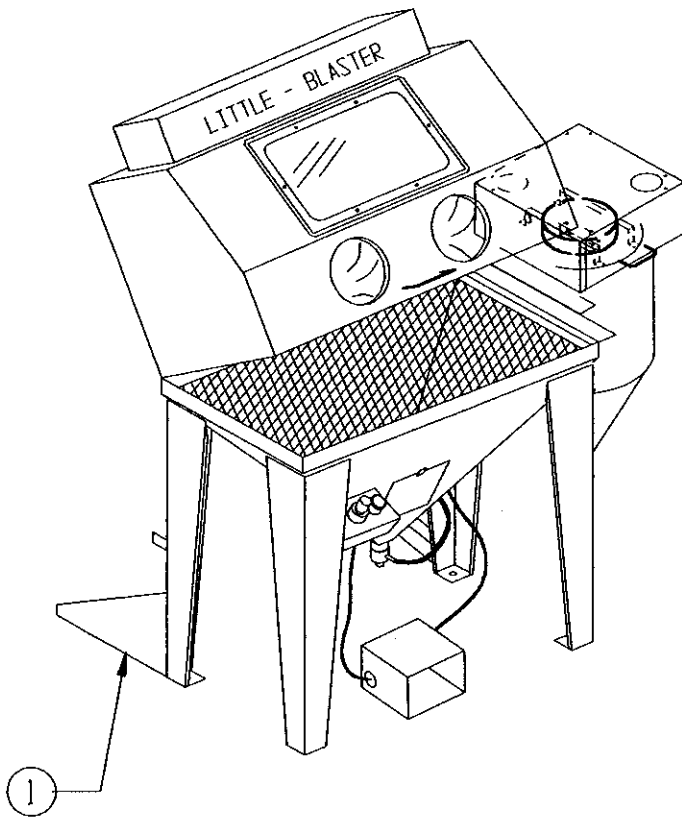

Figure 8

WARRANTY

Larry Hess & Associates, Inc. Warrants to the original purchaser the merchandise sold to be free from defects in material and workmanship under normal use and service for a period of one (1) year. Upon prompt notification by the buyer, to LHA, components that are determined by LHA to be defective will be repaired or replaced at no additional charge, F.O.B. our factory.

Manufacturer shall have the right to inspect prior to replacing all merchandise in question.

This warranty does not apply to parts that are directly involved in the blasting operation. Example: gun, gun parts, viewing window, hose, gloves, etc.

Manufacturer shall not be required to pay any removal or installation charges whatsoever under this warranty.

Manufacturer shall not be liable for prospective profits, special or consequential damages, nor shall any recovery of any kind against manufacturer be greater in amount than the cost of repairs of defects in workmanship.

This warranty does not apply to damage caused by accidents, damage in transit, alterations by unauthorized personnel, abuse or damage by flood, fire, or acts of God, nor by artificially generated electric currents or any other cause whatsoever except defects in material or factory workmanship.

In all cases, defective parts must be returned to Larry Hess & Associates, Inc. before credit is issued.

If genuine BLAST-IT-ALL® replacement parts are not used, the warranty is void.

This warranty is in lieu of all other warranties expressed or implied and releases Larry Hess & Associates, Inc. of all other obligations and liabilities whatsoever. This warranty neither assumes nor authorizes any person to assume any obligation other than those specified by this warranty.

WARNING

DO NOT USE SAND. SAND WILL CAUSE SILICA DUST, WHICH IS THE CAUSE OF SILICOSIS DISEASE, A CONDITION OF MASSIVE FIBROSIS OF THE LUNGS. THIS STATEMENT INDICATES POTENTIAL PERSONNEL HAZARD. FAILURE TO COMPLY WITH THESE INSTRUCTIONS MAY RESULT IN PERSONAL INJURY.

BLAST-IT-ALL®
Larry Hess & Associates, Inc.
Airport Industrial Park
185 Piper Lane
P.O. Box 1615
Salisbury, NC 28145-1615