

**THE MAGNUM™**  
**SUCTION SYSTEM**

**MANUAL NUMBER: 564**  
**TABLE OF CONTENTS**

<b>PAGE</b>	<b>FIGURE</b>	
<b>1</b>	<b>-</b>	<b>SET-UP INSTRUCTIONS</b>
<b>2</b>	<b>-</b>	<b>OPERATING INSTRUCTIONS</b>
<b>3</b>	<b>-</b>	<b>GENERAL MAINTENANCE</b>
<b>4</b>	<b>1</b>	<b>STANDARD CABINET PARTS</b>
<b>5</b>	<b>2</b>	<b>AIR CONTROL, PARTS</b>
<b>6</b>	<b>3</b>	<b>MACHINE LIGHTING, PARTS</b>
<b>7</b>	<b>4</b>	<b>BLAST GUN, PARTS</b>
<b>8</b>	<b>5</b>	<b>400 CFM RECLAIM, PARTS</b>
<b>9</b>	<b>6</b>	<b>600 CFM RECLAIM, PARTS</b>
<b>10</b>	<b>-</b>	<b>ELECTRICAL DIAGRAM</b>
<b>11</b>	<b>-</b>	<b>MACHINE WARRANTY</b>
<b>12</b>	<b>-</b>	<b>WARRANTY REGISTRATION FORM</b>

**WARNING**

**DO NOT USE SAND.** SAND WILL CAUSE SILICA DUST, WHICH IS THE CAUSE OF SILICOSIS DISEASE, A CONDITION OF MASSIVE FIBROSIS OF THE LUNGS. THIS STATEMENT INDICATES POTENTIAL PERSONNEL HAZARD.  
**FAILURE TO COMPLY WITH THESE INSTRUCTIONS  
MAY RESULT IN PERSONAL INJURY.**

WEBSITE CONCERNING SILICOSIS:  
[http://www.osha.gov/Silica/IT69D\\_1.html](http://www.osha.gov/Silica/IT69D_1.html)

## SET-UP INSTRUCTIONS

### **MACHINES / RECLAIMS WITH DUST BAG**

**\*\*\* READ BEFORE OPERATING EQUIPMENT \*\*\***

1. Remove plastic from machine.
2. Remove lag bolts from each of the four legs, then remove machine from the pallet.
3. Attach filter bag to BLOWER outlet with hose clamp
4. Connect motor male plug, to female plug cord from the light box.
5. Connect compressed air supply to fitting provided on left rear leg of the machine. Air piping should be of the same size as the connection point, offering no restriction to flow.  
**(DO NOT USE QUICK-DISCONNECTS)**
6. Connect the factory installed ELECTRICAL cord from light box, to a 120-Volt, 60 HZ, 1 Phase power supply. A 20 AMP breaker or fuse should be used.

**MAKE SURE MACHINE IS PROPERLY GROUNDED.**

# OPERATING INSTRUCTIONS MACHINE WITH RECLAIM

\*\*\* READ BEFORE OPERATING EQUIPMENT \*\*\*

## 1. Preparing parts for Blasting:

All parts to be processed must be free of oil, grease, and moisture. Make sure parts are dry before putting into cabinet for cleaning.

## 2. Air Pressure:

Set air pressure at 80 PSIG. Most parts for blasting cleaning cabinet should be blasted at 80 psi. Designate parts to be processed, start at lower pressure and work up the PSI scale to obtain desired finish.

\*\*\*WARNING\*\*\*

DO NOT CONNECT TO HIGH PRESSURE BOTTLE GAS, RUPTURE AND EXPLOSION CAN OCCUR.

## 3. Gun Angle and Distance:

Direct blast at part with an approximate (45-60) degree angle with ricochet toward the back side of cabinet. Do not hold at 90 degree to part being processed. This will cause the media to blast to bounce back into the blast stream and slow blasting action. Also 90-degree angle will cause excessive wear on gun and viewing window. Hold gun approximately 6 inches from part being cleaned.

\*\*\*WARNING\*\*\*

GUN MUST ALWAYS BE POINTED AWAY FROM THE OPERATOR AND TOWARD ITEM BEING PROCESSED. NEVER BLAST WITH ANY OF THE CABINET DOORS OPEN. WHILE LOADING AND UNLOADING, NO ONE SHOULD BE AT THE OPERATOR STATION AT FRONT OF THE BLAST CABINET.

## 4. Media:

Media should be good quality and dry. Damp media will cause the media not to flow and will clog abrasive flow. NEVER USE SAND. See **\*\*CAUTION\*\***, below. If you are having a problem selecting media for a specified job, contact your distributor for their recommendations.

**\*\*CAUTION\*\***

**\*\*CAUTION\*\***

**DO NOT USE SAND BLASTING SAND. THIS WILL CAUSE SILICA DUST WHICH IS THE CAUSE OF SILICOSIS DISEASE, A CONDITION OF MASSIVE FIBROSIS OF THE LUNGS.**

# MAINTENANCE INSTRUCTIONS MACHINE WITH RECLAIM

\*\*\* READ BEFORE OPERATING EQUIPMENT \*\*\*

## 1. **Blasting Gun:**

After 10 - 12 hours of blasting time the air orifice and nozzle should be checked. If the nozzle shows wear, rotate 1/4 turn to prevent uneven wear. If this is not checked, it could result in destruction of nozzle and damage to the gun housing. If wear is detected on the orifice tip, replace.

## 2. **Caking of Media:**

- A. Media caking is caused by moisture in compressed air supply or oily and greasy parts. If this is not corrected, media will not flow and will clog gun. Check air supply. If water or moisture is present, install a good moisture trap. If oily or greasy parts are being blast treated, you should first degrease and dry parts.
- B. If blast gun should occasionally clog, place thumb over nozzle (hold tight) and push foot valve down 3 to 4 seconds. This will cause the system to back blast through the gun and media hose, and clear the media hose.

## 3. **Gun Air Pressure Drop:**

Set air regulator at 80 PSI on air gauge. Push foot valve and if gauge reading should drop, check the air supply pipe or hose. A restriction in the supply line such as reducers or quick couplers will cause pressure drop. Also, if the blast cabinet is too far from the air compressor, a pressure drop can occur. We recommend 1/2" - 1" I.D. air supply line. The bigger the better.

## 4. **Poor Visibility - Excessive Dust:**

- A. Cabinet Air inlet blocked, check for blockage.
- B. Dust collector bag needs emptied.
- C. With motor off, grasp bag and shake
- D. Media breakdown - replace media and clean dust collector.

## 5. **Poor Media Flow:**

- A. Wet or damp media caused from moisture or oil in compressed air line.
- B. Use dry air or install a moisture filter.
- C. Replace media and clean media sump and hose.
- D. Media level should be below media screen.
- E. Hole in media hose from wear, replace hose assembly.

**\*\*CAUTION\*\***

**\*\*CAUTION\*\***

**DO NOT USE SAND BLASTING SAND. THIS WILL CAUSE SILICA DUST WHICH IS THE CAUSE OF SILICOSIS DISEASE, A CONDITION OF MASSIVE FIBROSIS OF THE LUNGS.**

# THE MAGNUM

## STANDARD CABINET PARTS

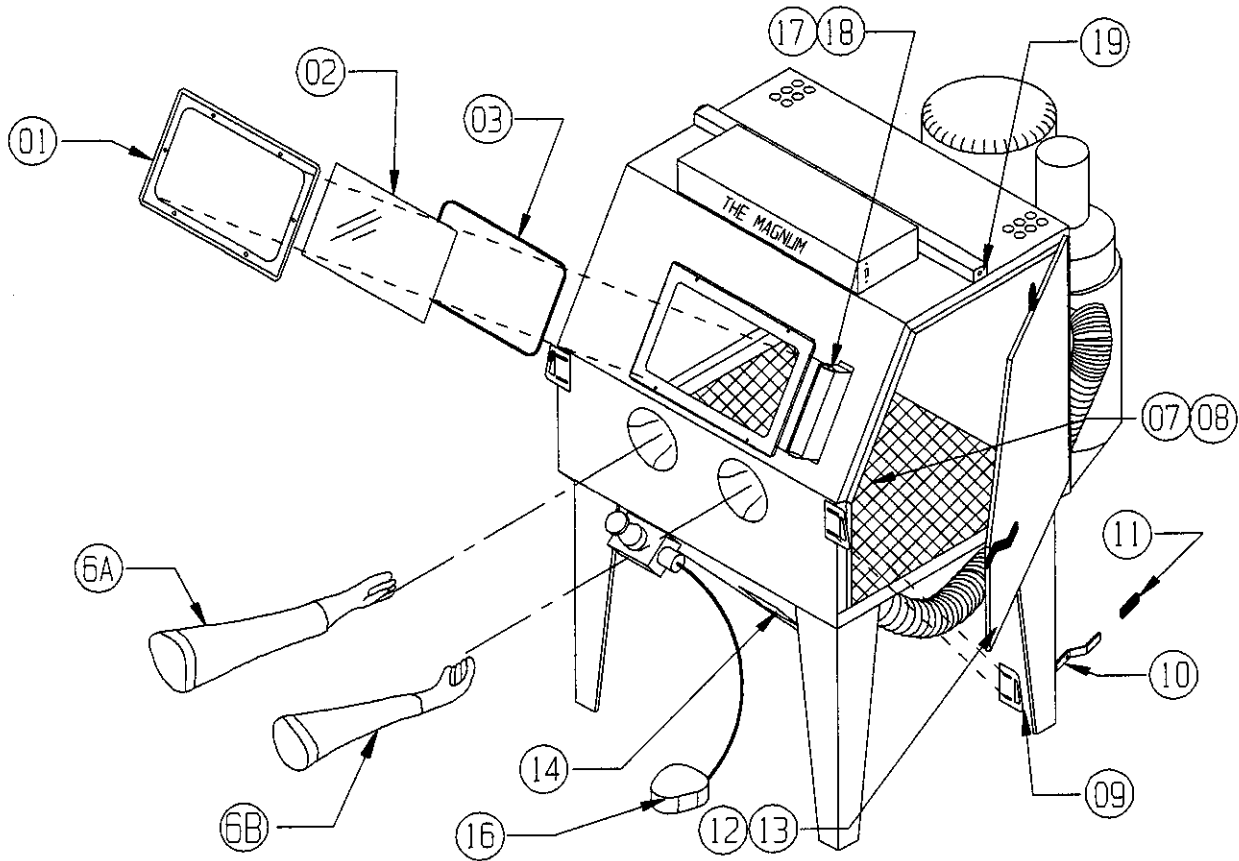

ITEM NO.	PART NO.	DESCRIPTION
01	23-053	WINDOW FRAME
02	23-050	WINDOW, VIEWING
03	24-054-64	WINDOW GASKET (64")
04	-----	-----
05	-----	-----
06	-----	-----
6A	22-111	GLOVE, SNAP-IN (LEFT ONLY)
6B	22-112	GLOVE, SNAP-IN (RIGHT ONLY)
7	10-152-44	GRATE, MODEL M-44
8	10-152-55	GRATE, MODEL M-55
9	15-730	DOOR STRIKER (EITHER SIDE)
10	15-719	DOOR CAM (EITHER SIDE)
11	15-720	DOOR CAM RUBBER GRIP
12	24-054-11'	DOOR GASKET MODEL M-44
13	24-054-13'	DOOR GASKET MODEL M-55
14	24-055	SUMP DOOR GASKET
15	-----	-----
16	15-743	FOOT BLAST CONTROL
17	011191	MYLAR GLASS PROTECTOR (OPTIONAL X 12-1/2" x 10')
18	011190	MYLAR HOLDER (OPTIONAL)
19	13-512	SWITCH, PUSH VALVE, SAFETY DOOR

**FIGURE 1**  
**PAGE 4**

# THE MAGNUM MACHINE AIR CONTROLS

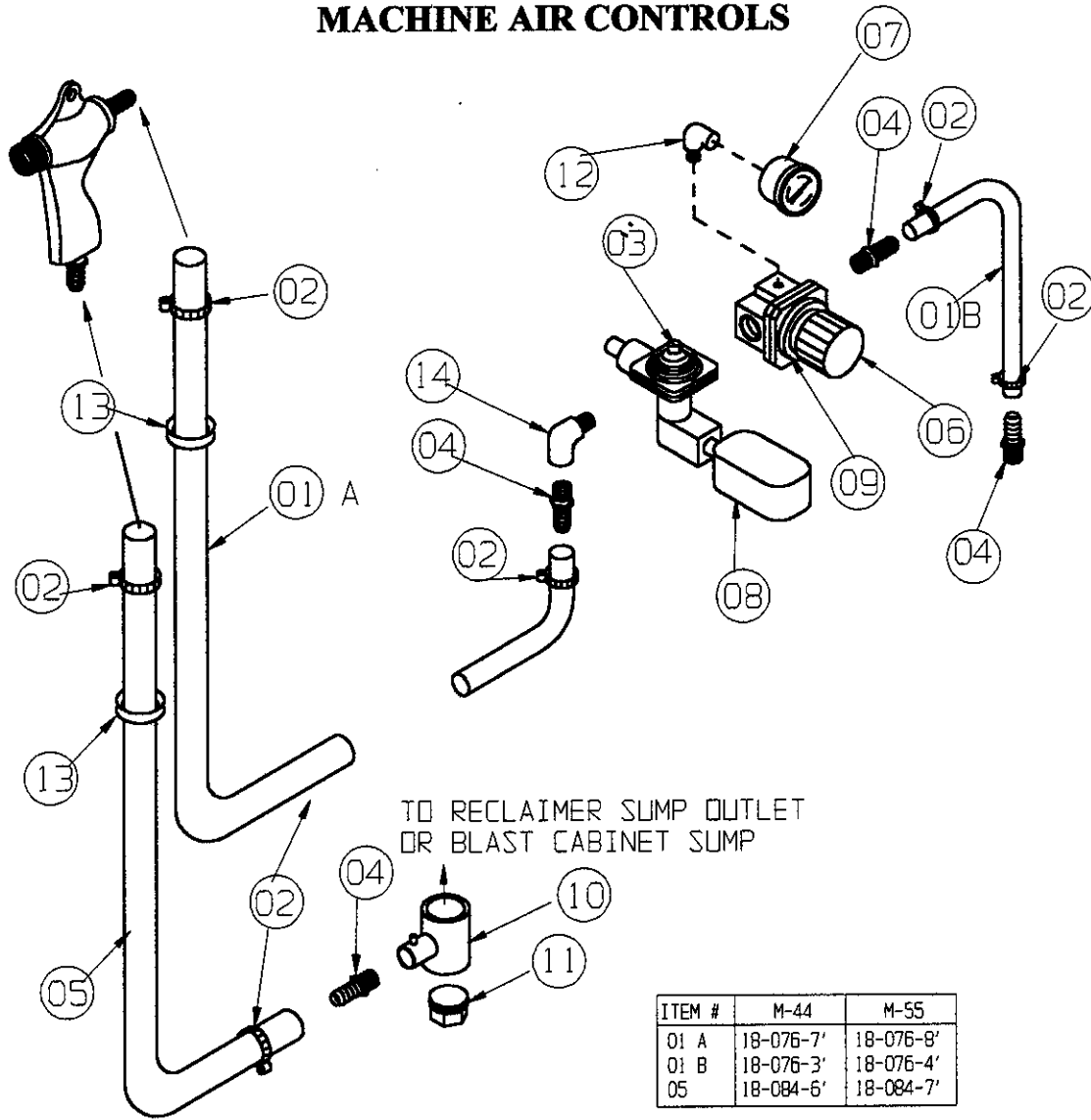

ITEM NO.	PART NO.	DESCRIPTION
1	18-076	HOSE, AIRLINE (SEE CHART)
2	21-032	CLAMP, HOSE
3	13-514	SOLENOID, 1/2"
4	14-301	FITTING, 1/2" HOSE x 1/2" MPT
5	18-084	HOSE, MEDIA LINE (SEE CHART)
6	16-965	REGULATOR, AIR 1/2"
7	16-820	GAUGE, AIR
8	13-571	JUNCTION BOX 2" x 4"
9	16-965LR	REGULATOR LOCK RING
10	20-200	MEDIA VALVE (COMPLETE)
11	20-201	PLUG (MEDIA VALVE)
12	14-524	1/4" STREET ELBOW
13	24-050	GROMMET, HOSE
14	14-372	1/2" STREET ELBOW

**FIGURE 2  
PAGE 5**

# THE MAGNUM LIGHT BOX

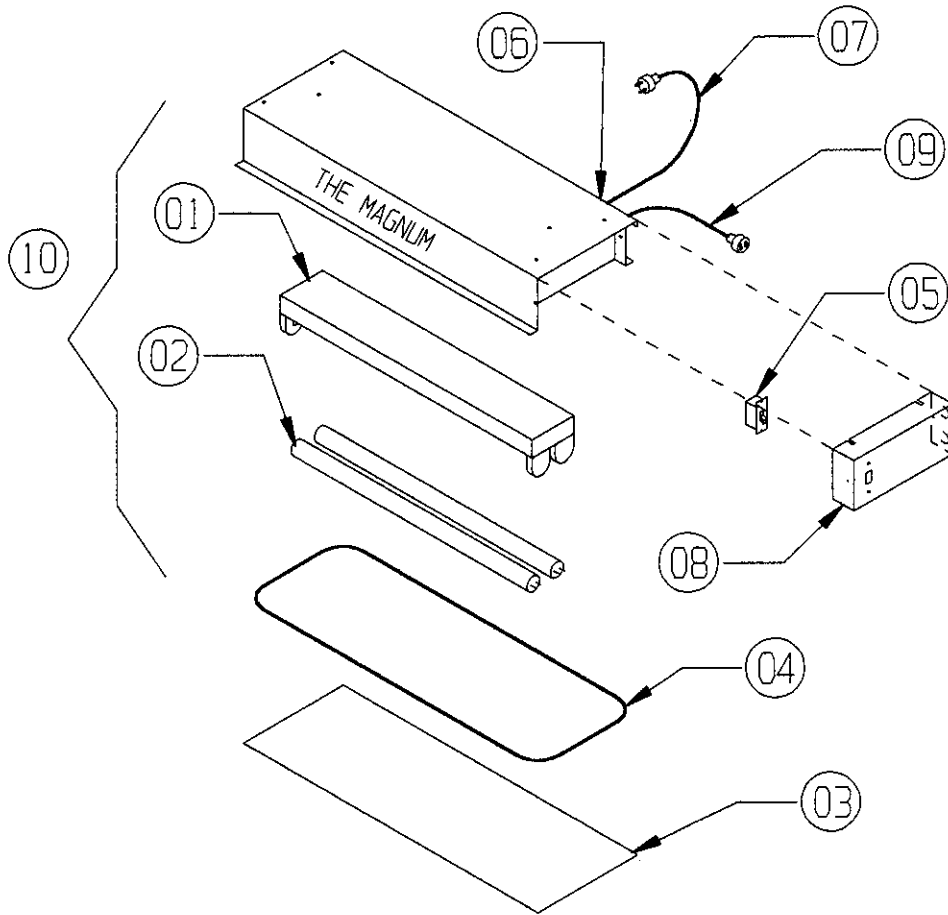

ITEM NO.	PART NO.	DESCRIPTION
1	13-533	FLUORESCENT FIXTURE, (NO TUBES)
2	13-534	FLUORESCENT TUBE
3	010216	PROTECTOR, LIGHT
4	23-059	GASKET
5	13-655	SWITCH
6	13-605	ROUND CONNECTOR
7	13-550	POWER CORD, 3 WIRE
8	B198-2	SWITCH MOUNTING PLATE
9	010172F	CORD WITH FEMALE PLUG
10	010800	COMPLETE LIGHT BOX (EXCEPT 3 & 4)

**THE MAGNUM  
BLAST GUN ASSEMBLY**

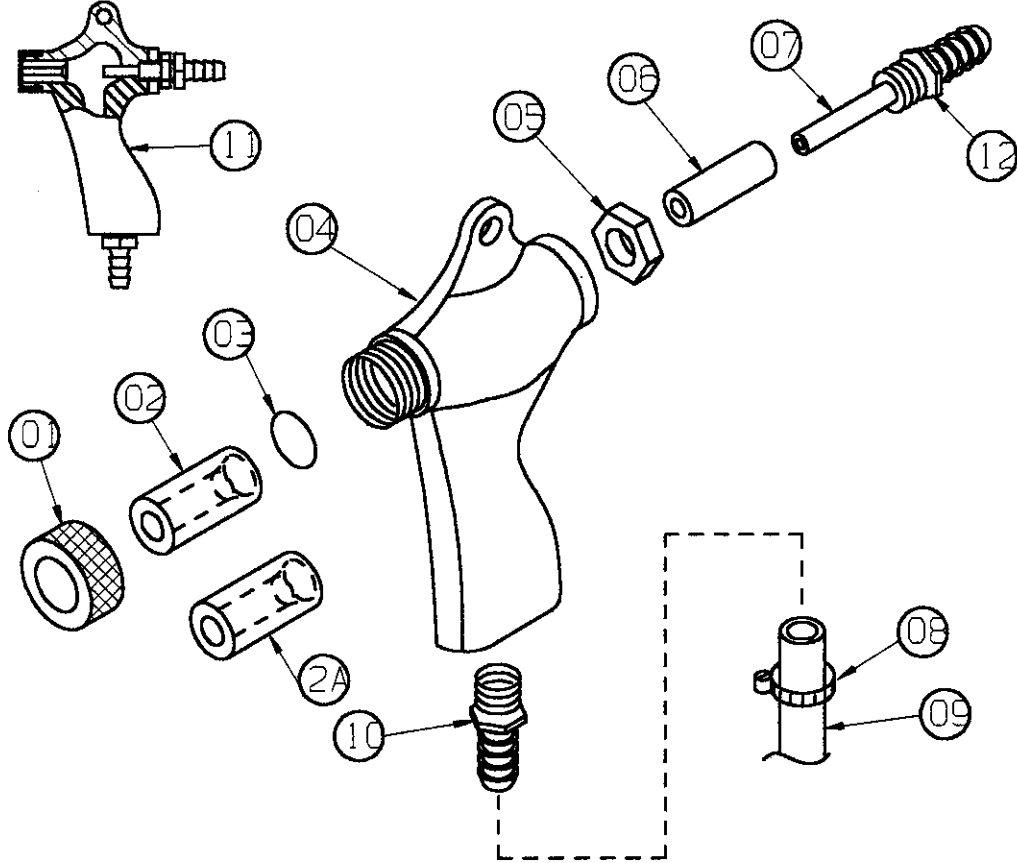

ITEM NO.	PART NO.	DESCRIPTION
1	20-054	NOZZLE NUT HOLDING
2	20-074	NOZZLE CERAMIC, 1/4" I.D. SIZE 4
2	20-075	NOZZLE CERAMIC, 5/16" I.D. SIZE 5
2	20-076	NOZZLE CERAMIC, 3/8" I.D. SIZE 6
2A	20-084	NOZZLE CARBIDE, 1/4" I.D. SIZE 4
2A	20-085	NOZZLE CARBIDE, 5/16" I.D. SIZE 5
2A	20-086	NOZZLE CARBIDE, 3/8" I.D. SIZE 6
3	20-053	"O" RING - NOZZLE SEALING
4	20-040	GUN BODY ONLY
5	20-052	LOCKNUT, DRIFICE
6	20-063	RUBBER COVER, DRIFICE
7	20-064	DRIFICE AIR 4/32" I.D. SIZE 4 INCLD. #6 & 7
7	20-065	DRIFICE AIR 5/32" I.D. SIZE 5 INCLD. #6 & 7
7	20-066	DRIFICE AIR 6/32" I.D. SIZE 6 INCLD. #6 & 7
8	21-032	CLAMP, HOSE
9	18-084	HOSE, MEDIA 1/2" I.D. (SPECIFY LENGTH)
10	14-302	FITTING-HOSE TO GUN 1/2" HOSE x 3/8" MPT
11	20-041	GUN, STD. COMP. W/CERAMIC NOZZLE (SPECIFY SIZE)
11	20-042	GUN, STD. COMP. W/CARBIDE NOZZLE (SPECIFY SIZE)
12	-----	GUN SIZE IS STAMPED ON AIR DRIFICE HEX

**FIGURE 4  
PAGE 7**



# THE MAGNUM 400 RECLAIMER

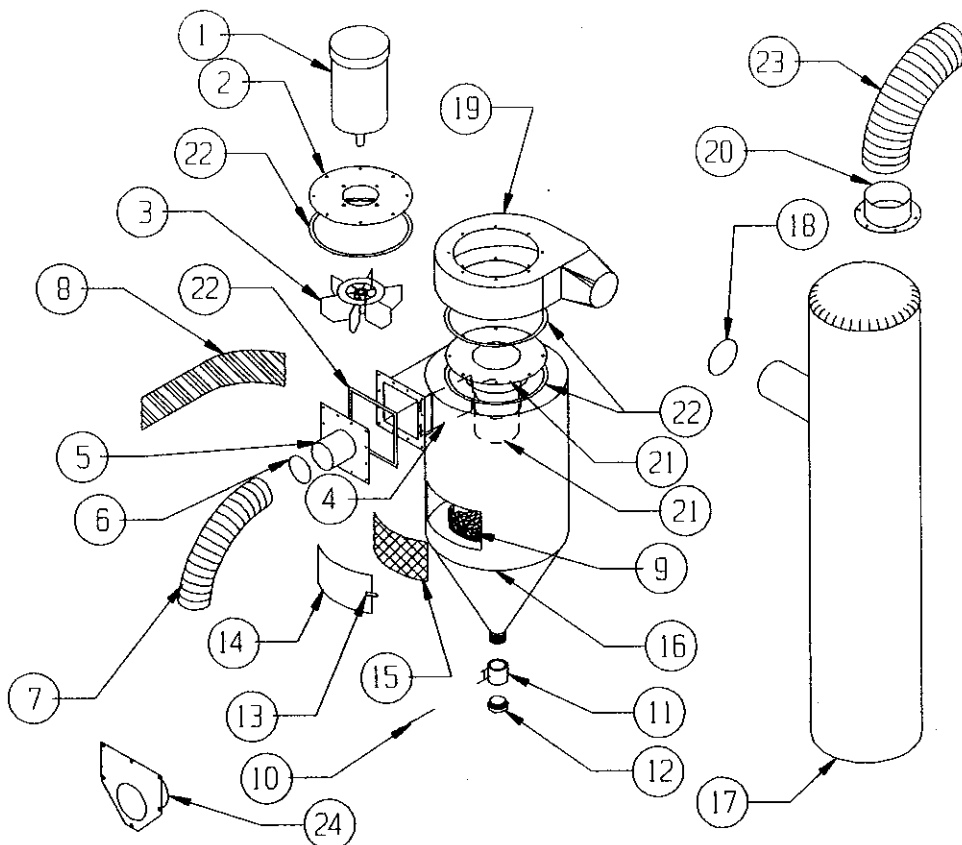

ITEM #	400 CFM	DESCRIPTION
1	13-400	MOTOR, 1/2 HP
2	11-420	MOTOR PLATE
3	11-418	BLADE
4	11-428	BAFFLE
5	11-405	INLET ADAPTOR
6	21-034	CLAMP
7	19-092-6'	FLEX HOSE 4" 6' LONG
8	11-417	INLET WEAR PLATE (OPTIONAL)
9	11-406	STD. SCREEN BASKET
9	11-429	BASKET, HEAVY DUTY (OPTIONAL)
10	14-301	FITTING, 1/2" x 1/2"
11	20-200	MEDIA VALVE, 2"
12	20-201	DRAIN PLUG
13	15-728	DOOR LATCH & CATCH ASMB.
14	11-402	DOOR AND GASKET
15	11-403	GASKET (ONLY)
16	11-401	RECLAIMER HOUSING
17	11-415	DUST BAG
18	21-036	CLAMP
19	11-416	BLOWER HOUSING
20	002028	TOP OUTLET (USED WITH DUST COLLECTOR) 6"
21	11-431	INNER VACUUM TUBE WITH SLIDE TUBE
22	24-030-3	PUTTY TAPE 3'
23	19-096	FLEX HOSE, 6" TO DUST COLLECTOR (USE WITH #20 & DUST COLLECTOR)
24	A650-4	MACHINE SUMP ADAPTOR, 4"

**FIGURE 5**  
**Page 8**

# THE MAGNUM 600 RECLAIMER

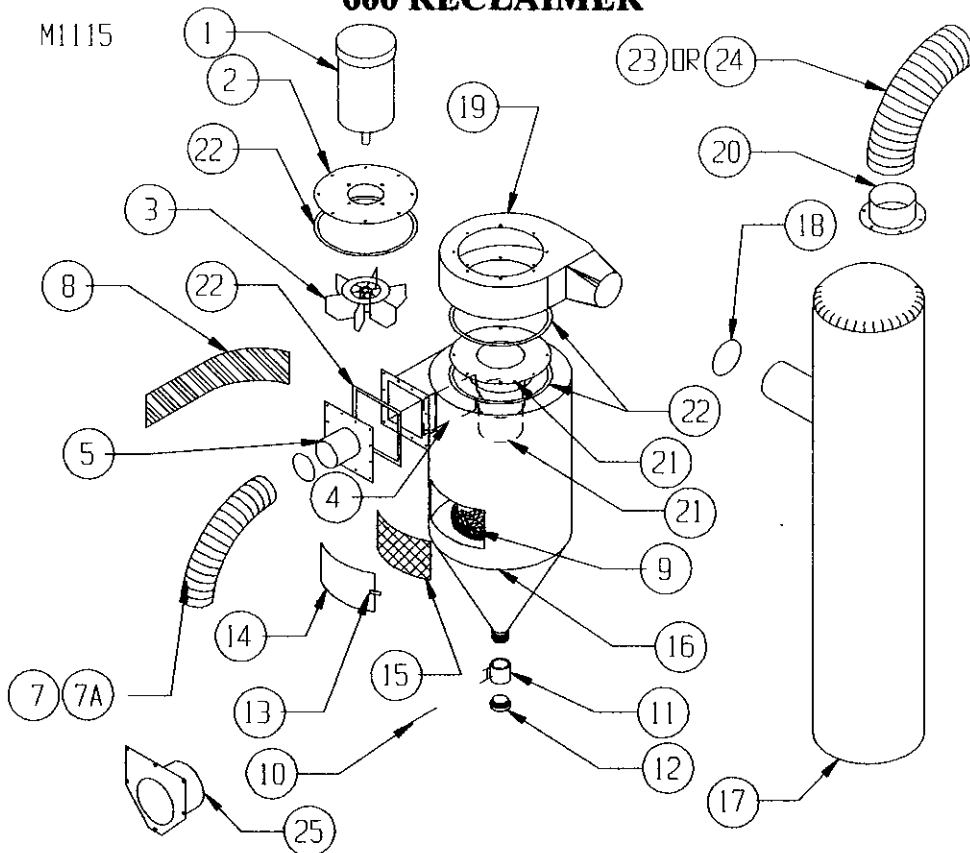

ITEM #	600 CFM	DESCRIPTION
1	13-700	MOTOR, 1 HP
2	11-720	MOTOR PLATE
3	11-718	BLADE
4	11-728	BAFFLE
5	11-705	INLET ADAPTOR
6	21-034	CLAMP
7	19-094-6'	FLEX HOSE 5" MODEL M-44
7 A	19-094-7'	FLEX HOSE 5" MODEL M-55
8	11-717	INLET WEAR PLATE (OPTIONAL)
9	11-706	STD. SCREEN BASKET
9	11-729	BASKET, HEAVY DUTY (OPTIONAL)
10	14-301	FITTING, 1/2" x 1/2"
11	20-200	MEDIA VALVE, 2"
12	20-201	DRAIN PLUG
13	15-728	DOOR LATCH & CATCH ASMB.
14	11-702	DOOR AND GASKET
15	11-703	GASKET (ONLY)
16	11-701	RECLAIMER HOUSING
17	11-715	DUST BAG
18	21-036	CLAMP
19	11-716	BLOWER HOUSING
20	002028	TOP OUTLET (USED WITH DUST COLLECTOR)
21	11-731	INNER VACUUM TUBE WITH SLIDE TUBE
22	24-030-3	PUTTY TAPE, 3'
23	19-096-6'	FLEX HOSE, 6" TO DUST COLLECTOR (USE WITH #20 & DUST COLLECTOR) MODEL M-44
24	19-096-7'	FLEX HOSE, 6" TO DUST COLLECTOR (USE WITH #20 & DUST COLLECTOR) MODEL M-55
25	A650-5	MACHINE SUMP ADAPTOR, 5"

**FIGURE 6**  
**Page 9**

# THE MAGNUM ELECTRICAL DIAGRAM

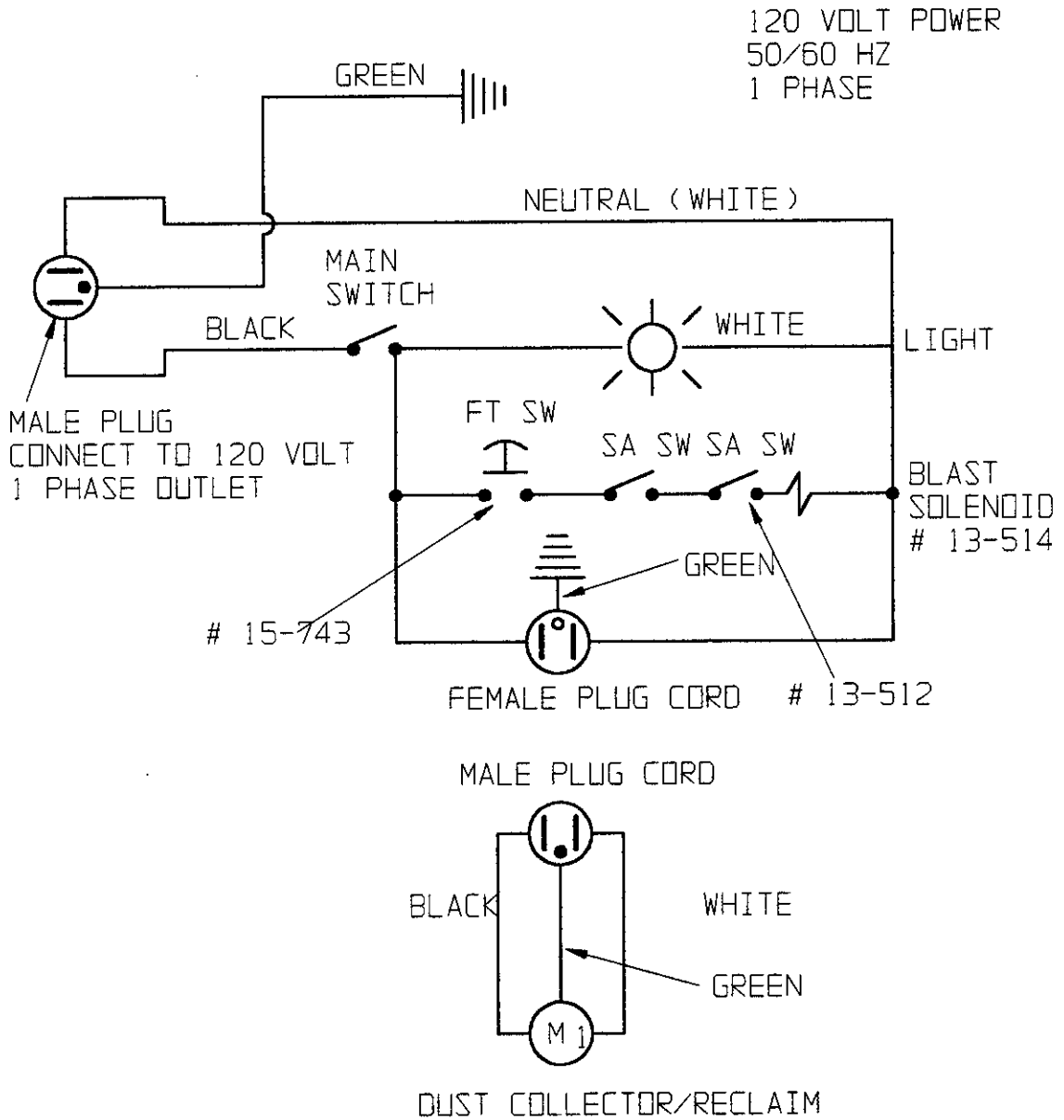

**FIGURE 7  
PAGE 10**

## WARRANTY

Larry Hess & Associates, Inc. Warrants to the original purchaser the merchandise sold to be free from defects in material and workmanship under normal use and service for a period of one (1) year. Upon prompt notification by the buyer, to LHA, components that are determined by LHA to be defective will be repaired or replaced at no additional charge, F.O.B. our factory.

Manufacturer shall have the right to inspect prior to replacing all merchandise in question.

This warranty does not apply to parts that are directly involved in the blasting operation. Example: gun, gun parts, viewing window, hose, gloves, etc.

Manufacturer shall not be required to pay any removal or installation charges whatsoever under this warranty.

Manufacturer shall not be liable for prospective profits, special or consequential damages, nor shall any recovery of any kind against manufacturer be greater in amount than the cost of repairs of defects in workmanship.

This warranty does not apply to damage caused by accidents, damage in transit, alterations by unauthorized personnel, abuse or damage by flood, fire, or acts of God, nor by artificially generated electric currents or any other cause whatsoever except defects in material or factory workmanship.

In all cases, defective parts must be returned to Larry Hess & Associates, Inc. before credit is issued.

If genuine BLAST-IT-ALL® replacement parts are not used, the warranty is void.

This warranty is in lieu of all other warranties expressed or implied and releases Larry Hess & Associates, Inc. of all other obligations and liabilities whatsoever. This warranty neither assumes nor authorizes any person to assume any obligation other than those specified by this warranty.

## WARNING

**DO NOT USE *SAND*. SAND WILL CAUSE SILICA DUST, WHICH IS THE CAUSE OF SILICOSIS DISEASE, A CONDITION OF MASSIVE FIBROSIS OF THE LUNGS. *THIS STATEMENT INDICATES POTENTIAL PERSONNEL HAZARD. FAILURE TO COMPLY WITH THESE INSTRUCTIONS MAY RESULT IN PERSONAL INJURY.***

BLAST-IT-ALL®  
Larry Hess & Associates, Inc.  
Airport Industrial Park  
185 Piper Lane  
P.O. Box 1615  
Salisbury, NC 28145-1615