

# BLAST-IT-ALL®

## WARNING

DO NOT USE *SAND*. SAND WILL CAUSE SILICA DUST, WHICH IS THE CAUSE OF SILICOSIS DISEASE. A CONDITION OF MASSIVE FIBROSIS OF THE LUNGS. ***THIS STATEMENT INDICATES POTENTIAL PERSONNEL HAZARD. FAILURE TO COMPLY WITH THESE INSTRUCTIONS MAY RESULT IN PERSONAL INJURY.***

***WEBSITE FOR SILICOSIS:***

***[http://www.osha.gov/Silica/IT69D\\_1.html](http://www.osha.gov/Silica/IT69D_1.html)***

**LARRY HESS AND ASSOCIATES, INC.**

**185 PIPER LANE**

**SALISBURY, NC 28144 USA**

**800-535-2612**

**FAX: 704-638-9311**

**EQUIPMENT MANUAL**

**NUMBER MM-589**

**BB2**

**BB2R**

**DATE: July 5, 2006**

## TABLE OF CONTENTS

	Page
List of Illustrations	1
<b>Section 1 Installation:</b>	
1.0 Description	2
1.1 Unpacking	2
1.2 Placement	2-3
1.3 Compressed Air Supply	3-4
1.4 Pre-Start Adjustments	4-6
<b>Section 2 Operation:</b>	
2.1 Media Loading	6
2.2 Parts Loading	6
2.3 Test Parts Flow	6
2.4 Adjust Blast Pressure	6
2.5 Adjust Blast Guns	6-7
2.6 Test Blast	7
2.7 Blow-Off Adjustments	7
2.8 Media Types	7
2.9 Parts Unloading	7-8
<b>Section 3 Maintenance:</b>	
3.1 Drive Train	8-9
3.2 Blast System	9-10
3.3 Dust Collection	10
3.4 Cabinet	10-11
<b>Section 4 Trouble Shooting:</b>	
4.1 Good Media Carried Over To Dust Collector	11
4.2 Reclaim System Does Not Convey Media	11-12
4.3 Poor Blast Performance	13
<b>Table:</b>	
<b>Air Consumption Table</b>	<b>14</b>
<b>Illustration Drawings and Photos</b>	<b>15-32</b>

## LIST OF ILLUSTRATIONS

ISOMETRIC CABINET DRAWING.....	B14017
CABINET FRONT VIEW.....	PHOTO
CABINET SIDE VIEW.....	PHOTO
CABINET REAR VIEW.....	PHOTO
BARREL ASS'Y.....	B14018-M
WINDOW & LATCH REPLACEMENT PARTS.....	M143
AIR CONTROLS.....	B7119
GUN MOUNT DETAILS.....	A14140-M
GUN/NOZZLE.....	A9074
GEAR DRIVE.....	B14020
GEAR DRIVE COVER.....	A14138-M
RECLAIMER (700 CFM).....	M1115
DUST COLLECTOR (D-10).....	B2129
DUST COLLECTOR (M2-DC).....	M2079
700 CFM BLOWER REPLACEMENT PARTS.....	M12041
ELECTRICAL PANEL FRONT.....	B5218
ELECTRICAL PANEL LAYOUT.....	B5219
ELECTRICAL PANEL WIRING SCHEMATIC.....	B5217
ELECTRICAL BILL OF MATERIALS.....	B5217-1
TIMER MANUAL.....	
WARRANTY.....	

1.0 **DESCRIPTION:** The Model BB2 Barrel Blast System is designed to provide production media blast processing of various parts that tumble well within a rotating barrel. The electrical controls enable the operator to make initial adjustments and continue processing numerous batches of parts with reliable repeatability. The operator will only need to load and unload parts, the blast sequence occurs automatically.

1.1 **UNPACKING:** The Barrel Blaster is shipped on a skid, wrapped in stretch plastic. Be sure to inspect units for any damage immediately upon arrival and notify carrier before signing bill of lading. Carrier must be notified within 24 hours in any case.

1.1.1. Remove all protective coverings.

1.1.2. Open door on blast cabinet. Protecting hands and face, cut the two steel straps that hold barrel to drive axles. Open barrel door and remove light bulb, flex hose and clamps. Place light bulb in fixture. The flex hose will be connected to the pipe located at the bottom back side of cabinet hopper and to the reclaimer inlet once units are positioned. (If a reclaim unit is provided)

1.1.3. Place unit/s in vicinity of desired placement. Remove all lag screws holding unit/s to skid/s. Remove unit from skids with extreme caution, do not damage units.

1.1.4. Connect flex hose securely to cabinet and reclaimer.

1.1.5. Uncoil clear polyurethane blast hose at back of cabinet and insert the metal media inlet tube into its mating media feed tee located at the bottom of the media storage hopper on the reclaimer. There is an aspirator orifice located on the top of the media feed tee. The orifice may be adjusted by opening or closing the threaded adjustment and locking in place with lock nut. Open the bolt so one hole is open. This is an initial adjustment and may be changed later to richen or lean out media/air mixture. When the aspirator orifice is more open, the media/air mixture will be lean. When the aspirator orifice is more closed, the media/air mixture will be rich.

1.2 **PLACEMENT:** Locate cabinet and dust collector where there will be ample room to operate and maintain equipment. Be sure location is dry. Be sure compressed air and electrical utilities are accessible and

of adequate supply. Once satisfied with location, use concrete anchors to secure both cabinet and dust collector to concrete floor. The barrel will become heavy with parts, be sure cabinet is secure!

- 1.2.1 ELECTRICAL CONNECTION (MODEL BB2):** The Model BB2 is supplied with a 10 ga. power supply cable and 30 ampere connector. This shall be connected to a 120 VAC, 1 Ø, 60 HZ, 30 AMP circuit that is equipped with a user supplied circuit breaker, disconnect switch, and modern, intact grounding circuit. If three (3) phase controls were ordered as option, connect the appropriate power supply to L1, L2, L3 inside panel. Connect the blower motor cable to the mating terminals inside the T1, T2, T3 electrical panel. Suspend or support cable if necessary to keep out of way. The blower motor must rotate IN THE (direction of arrow). The rotation may be checked once power has been connected, make sure all switches on electrical panel face are "off", push the blower start and then stop. Check rotation.
- 1.3 COMPRESSED AIR SUPPLY:** The piping string for the unit is located at the back of the blast cabinet. The compressed air supply shall be clean, dry, oil free, 115 PSI. The Model BB2 requires a 1" NPT minimum air supply at 75 CFM minimum. On the system, additional CFM will be required if larger guns or higher blast pressure is to be used. Refer to Air Consumption Table for additional information. There shall be a user supplied relieving shut off valve before connection to unit. **DO NOT TURN "ON" COMPRESSED AIR SUPPLY UNTIL THE FOLLOWING IS COMPLETED.**
- 1.3.1. AIR PRESSURE REGULATOR:** Located on electrical panel face. Be sure knob is fully counter clockwise or "off".
- 1.3.2. AIR PRESSURE GAUGE:** Located on electrical panel face. It should read zero (0).
- 1.3.3. RECLAIMER VIBRATOR:** Connect yellow 1/4" poly tube located at back of unit (one loose end) to the push in fitting located on the reclaimer media storage hopper. Push tubing into fitting until it stops, then pull back on tubing. It should remain secure. If not, repeat.
- 1.3.4. RECLAIMER VIBRATOR REGULATOR:** Located on back of unit. The poly tube described in paragraph 1.3.3. originates here. Be sure knob is rotated fully counterclockwise or "off".

1.3.5. UNLOAD RAMP VIBRATOR REGULATOR: Located on back of unit above the reclaimer vibrator regulator. A 1/4" solenoid valve is located just after this regulator. Be sure knob is fully counterclockwise or "off".

1.3.6. LEAK CHECK: Be sure power to electrical panel is "on", all switches "off". Be sure all poly tubes on system are secure. Close door on blast cabinet. Slowly turn "on" air supply to unit. Listen for leaks. Use soapy water to locate leak if needed. Vibration from shipment may cause loosening of piping.

1.4 PRE-START ADJUSTMENTS: The following should be done prior to unit start up.

1.4.1. Turn power "off". Remove barrel door and position guns so they point slightly toward the center of the barrel and toward the back about 30 degrees from horizontal to start. Be sure all hoses are secure and will not interfere with rotation of barrel. Be sure the clear media hose HAS NO KINKS. Be sure light fixture is secure and will not interfere with rotation of barrel.

1.4.2. Turn air supply "on".

1.4.3. Turn power supply "on".

1.4.4. Turn knob on AIR PRESSURE REGULATOR clockwise so AIR PRESSURE GAUGE reads 100 PSI. Then turn counterclockwise so gauge reads 60 PSI. A relieving hissing sound should be audible as air pressure regulator equalizes. Leave at 60 PSI for initial start up.

1.4.5. Flip VIBRATOR SWITCH located on electrical panel face to "on" position. Go to back of unit and adjust UNLOAD RAMP VIBRATOR REGULATOR knob clockwise until a low intensity vibration of ramp is felt and heard. This is an initial adjustment, the regulator should be set for operation at the minimum level needed to allow free parts unloading and spent media flow through screen. Once adjusted, turn vibrator switch "off".

1.4.6. Turn knob on RECLAIMER VIBRATOR REGULATOR clockwise until a low intensity vibration level is achieved. If it is found that vibration is not needed during operation, the regulator may be turned "off".

1.4.7. Be sure the BARREL RPM CONTROL located on the panel face is in the zero (0) position. Open cabinet door and turn the ON-OFF-JOG switch in the "jog" position. Press the Jog button. Adjust the BARREL RPM CONTROL at different levels to check function of barrel rotation and speed control. When facing barrel, it should rotate toward you. !!! KEEP CLEAR OF ALL MOVING PARTS AT ALL TIMES TO AVOID SERIOUS BODILY INJURY !!! The barrel should stop whenever the JOG switch is released. There should be no compressed air escaping from blast guns or blow off jets as door interlock is not engaged. Check that all hoses, guns, fixtures are clear of barrel as it rotates.

1.4.8. Close cabinet door. Set CYCLE TIMER to 10 minute blast time. Flip ON-OFF-JOG switch to "on" position.

1.4.8.1 Set BLOW OFF TIMER to (60 seconds blow off time).

1.4.9. Be sure damper on blower is locked in the open position. Press BLOWER MOTOR switch to "on".

1.4.10. Flip LIGHT SWITCH to "on" position. Light should illuminate.

1.4.11. VIBRATOR SWITCH "OFF".

1.4.12. BARREL RPM CONTROL set to four (4) position on dial to start. Or set rotation speed as desired.

1.4.13. Press CYCLE START button (push to start). The following will occur.

A. Barrel rotates.

B. Compressed air exits blast gun. GREEN BLAST STATUS INDICATOR lamp illuminated.

C. CYCLE TIMER will count down as time cycle progresses.

E. Blast cycle reaches end. YELLOW BLAST STATUS INDICATOR lamp illuminated as blow off cycle starts.

F. If blast system is standard, blow off cycle will continue

As set on blow off timer as barrel rotates. At end of cycle, barrel stops, air blow off stops, RED BLAST STATUS INDICATOR lamp will illuminate. All cycles are now complete.

**!!! TO AVOID ELECTRIC SHOCK, SERIOUS INJURY OR DEATH, USE CAUTION WHENEVER ELECTRICAL ENCLOSURE DOOR IS OPENED**

1.4.14. Open blast cabinet door select JOG switch press "jog" position so barrel door is at front of cabinet. Unit is ready for media charging and operation.

## 2.0 OPERATION:

2.1 MEDIA LOADING: Be sure parts unload door is clamped closed. Dust collector blower motor is "on". SLOWLY dump a minimum of fifty (50) pounds of blast media into barrel door opening. Media will fall through barrel and unload ramp. Media will be conveyed from hopper via flex hose into media reclaimer. It will then be deposited into media storage hopper. **!!! DO NOT BREATHE DUST !!!** Note: Flex hose may build a static charge as media is being conveyed. Grounding the hose with a copper wire or using anti static solutions may alleviate the problem.

2.2 PARTS LOADING: Load parts into barrel. Do not fill barrel more than thirty percent (30%) as parts will not tumble and may fall from barrel.

\*Model BB2 - 325 pound capacity.

Replace barrel door. Secure with pins.

2.3 TEST PARTS FLOW: Close cabinet door securely. Select-JOG SWITCH press "jog" position and observe parts tumble action. Adjust barrel speed if needed. Fragile parts will need slow speeds. Parts should mix and flow in an even manner at random.

2.4 ADJUST BLAST PRESSURE: Fragile or soft parts will need lower blast pressures. Turn AIR PRESSURE REGULATOR knob to adjust blast pressure. Experience will dictate all blast adjustments.

2.5 ADJUST BLAST GUNS: ON-OFF-JOG SWITCH "off". Open cabinet door. Open barrel door. Visually observe position of blast



guns and where the blast stream from each gun will project. Adjust guns based upon observations when performing paragraph 2.3. The key is to give parts maximum exposure to blast stream as they tumble. As a rule the parts will be subject to greatest exposure as they reach their apogee, or highest point of travel before tumbling down to the bottom of barrel. Again, experience, trial and error will dictate final adjustments.

**2.6 TEST BLAST:** Secure barrel door. Secure cabinet door. Flip ON-OFF-JOG SWITCH to "on" position. Blower motor "on". Light "on". CYCLE TIMER at 10 minutes. BLOW OFF TIMER at 5 minutes. Press CYCLE START to initiate blast cycle. Observe the blast stream through the view window. Adjust the media feed tee to achieve a moderately lean mixture. Change gun angles, barrel speed, blast pressure and blast duration to achieve most efficient and desirable results. Again, experience, trial and error.

**2.7 BLOW OFF ADJUSTMENT:** If dust is retained on parts after blast and blow off cycles have ended, change the blow off to allow the barrel to rotate and the blow off cycle to be extended so retained dust and media are at a minimum.

**2.8 MEDIA TYPES:** The Model BB2 is suitable for use with all blast media types except metallic shot and grit. Very heavy grit of other types may provide marginal performance. If aggressive media is to be used, optional wear packages should be purchased and used. If not, the system will be subject to greater expense occurring from wear. Optional high static blowers may be purchased to convey heavy media types. Some media types may produce static charge. Grounding and anti static solutions will help.

**2.9 PARTS UNLOADING:** Once blasting is finished, the parts may be unloaded. Use caution. Do not breathe dust.

A. Place container under ramp. Be sure container will not move when parts are unloaded. Be sure container is large enough to catch all parts.

B. Flip VIBRATOR SWITCH "on". Allow to vibrate for a few seconds to allow any media to fall into hopper.

- C. Open parts unload door. Secure in holder.
- D. Use ON-OFF-JOG SWITCH to "jog" barrel so barrel door is facing operator. Remove door, place door and pins out of way.
- E. BARREL RPM CONTROL should be at about five (5) on dial.
- F. Hold ON-OFF-JOG SWITCH in the jog position to allow barrel rotation, parts will fall out of barrel, onto parts unload ramp and into container. In some instances, the barrel may need to be rotated until door faces operator. Any last few remaining parts may be removed.
- G. Be sure to close parts unload ramp before starting next blast cycle.

### 3.0 MAINTENANCE:

3.1 DRIVE TRAIN: The drive train consists of all components needed to rotate barrel. These components are:

3.1.1. DC MOTOR: The Model BB2 uses a 1/2 HP 90 VDC motor. The speed of the motor is controlled by the SCR circuit board located in the electrical panel. The operator externally adjusts barrel rotation speed by the BARREL RPM CONTROL knob. The motors do not need any maintenance procedures.

3.1.2. GEAR BOX: The motor is attached to the gear box providing power. The motor and gear box assembly are located on the right side of the cabinet underneath the protective shroud. With power to unit disconnected and locked off. The gear box does not require oil changing, but the gear lubricant level must be kept at plug level.

3.1.3. DRIVE CHAIN: The drive chain provides power transmission from the gear box output to the main rear barrel drive shaft. The

Motor/Gear box mounting bracket may be moved downward to tighten chain if it should stretch. Use any standard chain lube daily.

3.1.4. **SECONDARY DRIVE CHAIN:** Located under the shroud on the cabinet right side, this chain transmits power from the rear drive shaft to the front drive shaft. Tension is kept in this chain by a floating tensioning device.

3.1.5. **SHAFT BEARINGS:** Are protected by rubber seals located within the cabinet. These bearings must be greased daily to flush any contamination and to provide lubrication. The front and rear drive shafts pass through these bearings. If the rubber seals become worn, they must be replaced.

3.1.6. **DRIVE WHEELS:** Specially compounded, these wheels provide slip free rotation of barrel. The two set screws on each wheel must be checked daily for tightness. The wheels must be replaced if less than 1/8" of tread remains or wheels are unevenly worn.

3.1.7. **DRIVE SHAFT:** The drive shafts provide power to rotate the barrel. The shafts should be replaced if worn.

3.1.8. **DRIVE TRAIN OVERVIEW:** The drive train should be checked regularly to avoid complications or accumulative damage. Daily lubrication is a must. Be sure to shut off and lock out all electrical power to machine when servicing drive train.

3.2 **BLAST SYSTEM:** The blast system consists of the following items.

3.2.1. **BLAST GUNS:** The blast guns consist of a nozzle, air jet, mixing chamber, media inlet tube, and lock nut. These items must be maintained to assure proper function. Replace the nozzle if the ID is 1/8" or more larger than when it was new. Replace any parts that appear eroded from blast exposure.

3.2.2. **MEDIA HOSE:** A clear polyurethane that is extremely resistant to abrasion. This hose must be replaced when worn, kinked or soft.

3.2.3. **MEDIA FEED TEE AND MEDIA INLET TUBE:** The blast mixture is created here. Replace any parts if they appear eroded.

**3.2.4. MEDIA RECLAIMER:** Reclaims blast media as it is conveyed through system. Reclaimer should be checked for wear on a regular basis. The vibrating screen should be checked for tightness. Operating the vibrator at a minimum level will minimize loosening of bolt or cracking of screen. The flex hose connected to reclaimer should be replaced if worn and clamps tightened if they become loose.

**3.2.5. AIR HOSES:** Should be checked frequently for leaks or soft spots. Replace if needed.

**3.3 DUST COLLECTION:** The dust collector provides ventilation for blast cabinet and conveyance air for reclaimer. The following parts must be maintained to eliminate dust problems.

**3.3.1. FILTER BAGS:** Replace if worn, holes are found or blinded. Be sure clamps are tight.

**3.3.2. BAG SHAKER:** Shake filter bags daily to allow maximum air flow. Be sure blower motor is off when shaking filter bags.

**3.3.3. BLOWER:** The blower provides the ventilation air needed to operate dust collector. The blower motor does not need maintenance. The dust collector is fitted with an inlet damper to reduce air flow when using very fine media. The damper should always be locked into position. **!!! KEEP HANDS AND FACE OUT OF BLOWER !!!**

**3.3.4. DUST HOPPER:** Stores dust until it is disposed of. Be sure to comply with law in your area when disposing of dust. **!!! DO NOT BREATHE DUST !!!** Empty dust HOPPER daily.

**3.3.5. GASKETS:** Be sure all gaskets are in good condition and are adequately compressed. Replace if needed.

**3.4 CABINET:** The cabinet is the blast enclosure. Be sure to inspect the sheet metal for wear. Rubber should be placed at wearing areas. The vibrating ramp should be checked for tightness and wear. Be sure the vibrator is at the minimum required level. Replace any gaskets on cabinet if needed.

**3.4.1. PIPING:** Be sure the air line filter located on cabinet is emptied daily by turning petcock.

3.4.2. ELECTRICAL: No maintenance needed. Replace any fuses if needed.

#### 4.0 TROUBLE SHOOTING:

##### 4.1 GOOD MEDIA CARRIED OVER TO DUST COLLECTOR.

###### 4.1.1. New filter bags.

A. Continue use for 15 blasting hours so dust "cake" forms.

###### 4.1.2. Gaskets on dust collector or reclaimer worn/loose.

A. Tighten doors or replace gaskets.

###### 4.1.3. MEDIA COLLECTING ON VIBRATING DEBRIS SCREEN:

A. Clean screen of debris.

B. Vibrator is off. Turn vibrator on lightly.

C. Screen blinding. Near size particles are lodged in screen perforations. Consult dealer for screen with larger perforation size.

D. Media too large for screen. Consult dealer as above.

###### 4.1.4. BLOWER DAMPER TOO FAR OPEN:

A. Close damper just enough to correct. Lock damper after adjustment. ! KEEP BODY PARTS AND FACE CLEAR OF BLOWER DISCHARGE !

#### 4.2 RECLAIM SYSTEM DOES NOT CONVEY MEDIA:

##### 4.2.1. FILTER BAGS CLOGGED:

A. Shake bags with blower off to clean.

Empty dust hopper.

B. Bags worn out. Replace.

**4.2.2. BLOWER DAMPER TOO FAR CLOSED:**

A. Adjust so system conveys and retains good media. ! KEEP BODY PARTS AND FACE CLEAR OF BLOWER DISCHARGE !

**4.2.3. BLOWER ROTATION BACKWARDS:**

A. Qualified electrician to reverse motor connection.

**4.2.4. MEDIA ENTERING MEDIA CONVEYING HOSE AT TOO FAST RATE:**

A. Pour media into unit more slowly.

**4.2.5. GASKETS ON DUST COLLECTOR, RECLAIMER LEAKING:**

A. Tighten doors where gaskets are located.  
Replace gaskets if necessary.

**4.2.6. FLEX HOSE CONNECTIONS LOOSE:**

A. Check clamps and tighten if needed.

B. Replace hose if needed.

**4.2.7. WRONG MEDIA TYPE:**

A. The Model 2BBR is intended for use with non metallic media only.  
Change media.

## 4.3

### POOR BLAST PERFORMANCE:

#### 4.3.1. WORN BLAST GUN:

A. Replace any worn parts.

#### 4.3.2. KINKED OR WORN MEDIA HOSE:

A. Replace or reposition as needed.

#### 4.3.3. TOO LOW BLAST PRESSURE:

A. Adjust AIR PRESSURE REGULATOR to higher level.

#### 4.3.4. AIR COMPRESSOR TOO SMALL:

A. Provide adequate sized air compressor.

#### 4.3.5. AIR SUPPLY LINE TOO SMALL, RESTRICTED:

A. Be sure air supply line is of recommended size with non restrictive fittings.

#### 4.3.6. MEDIA FEED TEE IMPROPERLY ADJUSTED:

A. Adjust per paragraph 1.1.5

#### 4.3.7. MEDIA CAKED, WET OR OILY:

A. Change media. Use only clean, dry, oil free air.

## AIR CONSUMPTION TABLE

Air Jet Diameter	Nozzle Diameter	Cube Feet Per Minute At			Air Compressor Motor Size	
		60 PSI	80 PSI	100 PSI	Continuous Operation	Intermittent Operation †
1/8"	5/16"	16.5	21.5	22.5	5 H.P.	3 H.P.
*3/16"	*3/8"	37.5	47.5	57.5	10 H.P.	7 1/2 H.P.
1/4"	1/2"	67.0	85.0	103.0	20 H.P.	15 H.P.



B14017

NOTE: (16) DC VARIABLE SPEED DRIVE CHAIN DRIVE BOTH SHAFT 60:1 GEAR REDUCER.

(17) CONTROLS SAME AS UNIVERSAL PACKAGE WITH IMPROVEMENTS.

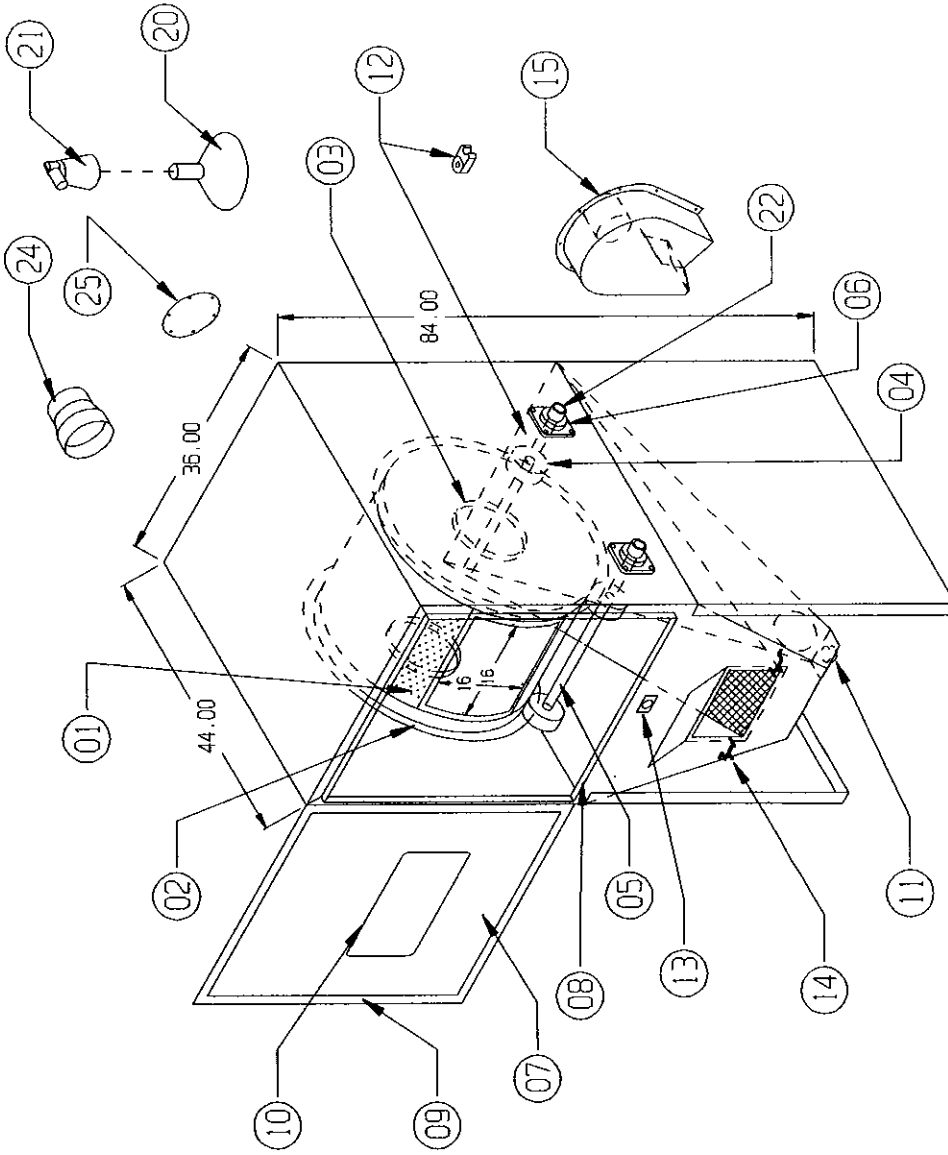

ITEM	QTY	DESCRIPTION	PART NO.
25	1	COVER PLATE	A14142
24	1	REDUCER FOR 700 CFM RECLAIMER	A35275
23	2	H.D. CABINET DOOR HINGE (NOT SHOWN)	
22	4	SLEEVE 7/8" x 1"	007524
21	1	LIGHT FIXTURE	010461
20	1	CABINET LIGHT BULB	010463
19	2	BIA OR UNIVERSAL GUN (NOT SHOWN)	
18	1	BLOW-OFF PACKAGE (NOT SHOWN)	
17	1	NOT SHOWN (SEE NOTE)	
16	1	NOT SHOWN (SEE NOTE)	
15	1	BIA SPIN OUT SEPARATOR	
14	2	DOOR TOGGLE CLAMPS	15-926-1
13	1	RAMP DOOR HOLDER MAGNET	011373
12	1	SCREEN VIBRATOR	16-919
11	1	MEDIA ADAPTOR W/ ADJ. MEDIA VALVE A9078	
10	1	BIA 12 1/2" x 21" WINDOW	
09	2	BIA DOOR LATCHES	
08	1	FLANGE SEAL	
07	1	180° SWING DOOR WITH 1" x 1/2" GASKET	
06	4	1" 4-BOLT BEARING W/BUSHING (A14136)	15-920
05	2	7/8" Ø SHAFT	A14139
04	4	5" Ø RUBBER/STEEL WHEEL W/BUSHING (A14136)	006780
03	2	10" Ø GUN PORT WITH 1" FLANGE	
02	2	11 GA. BARREL END GUIDE	
01	1	BARREL 11 GA. PERF PLATE WITH 3/16" HOLES	B14018

LARRY HESS & ASSOCIATES

ENGINEER	DEC	DATE	08/10/00	DWG. NO.	B14017
JOB NO.			SCALE: 1/16"		

REV	DESCRIPTION	BY	DATE
01			

B14018-M

NOTE: ALL PERFORATED PLATE 11 GA. WITH 3/16" HOLES

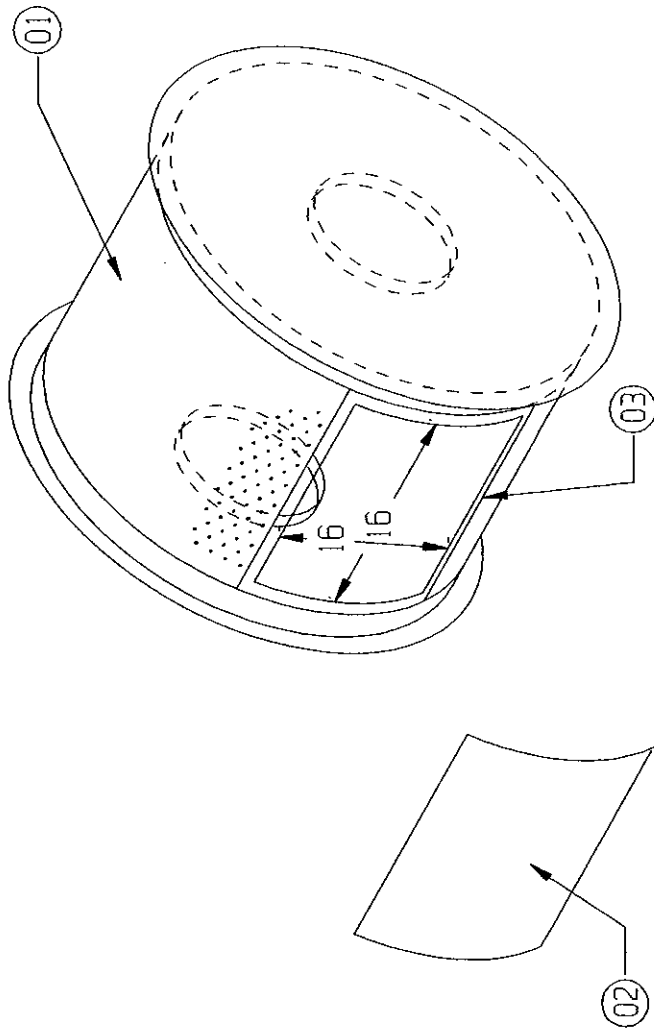

03	2	DOOR PIN	011372
02	1	BARREL DOOR	B14018-2
01	1	BARREL ASS'Y.	B14018
ITM	QTY	DESCRIPTION	PART NO.
<b>LARRY HESS &amp; ASSOCIATES</b>			
2.0 CU. FT. TUMBLE BARREL ASS'Y.		JOB NO.	SCALE:
			1/8"
ENGINEER	DEC	DATE	08/14/00
		DWG. NO.	B14018-M

REV	DESCRIPTION	BY	DATE
01			

**BLAST-IT-ALL®**

DESCRIPTION

STANDARD MACHINE REPLACEMENT PARTS

DATE

4/23/96

ENGINEER

DEC

DWG. NO.

M143

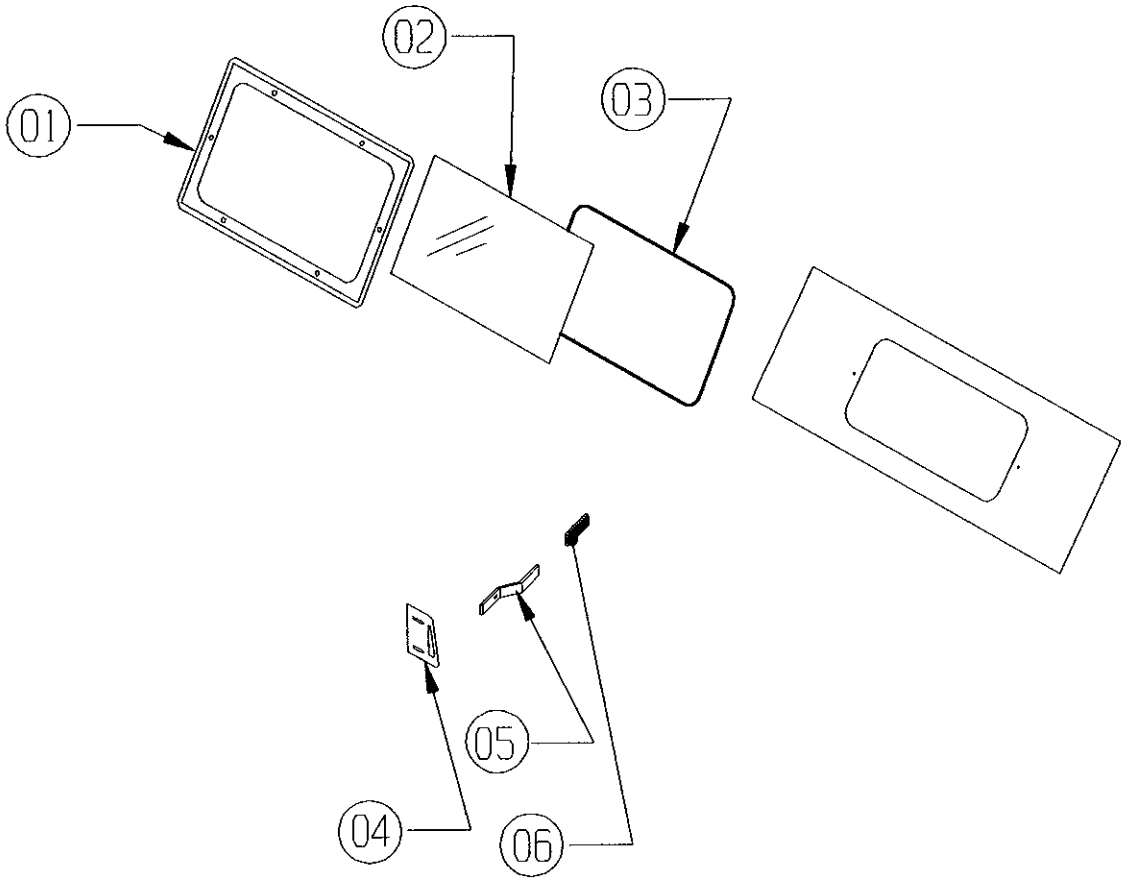

ITEM NO.	PART NO.	DESCRIPTION
1	23-053	WINDOW FRAME
2	23-050	WINDOW, VIEWING
3	24-059	WINDOW GASKET (SPECIFY LENGTH)
4	15-730	DOOR STRIKER (EITHER SIDE)
5	15-719	DOOR CAM (EITHER SIDE)
6	15-720	DOOR CAM RUBBER GRIP

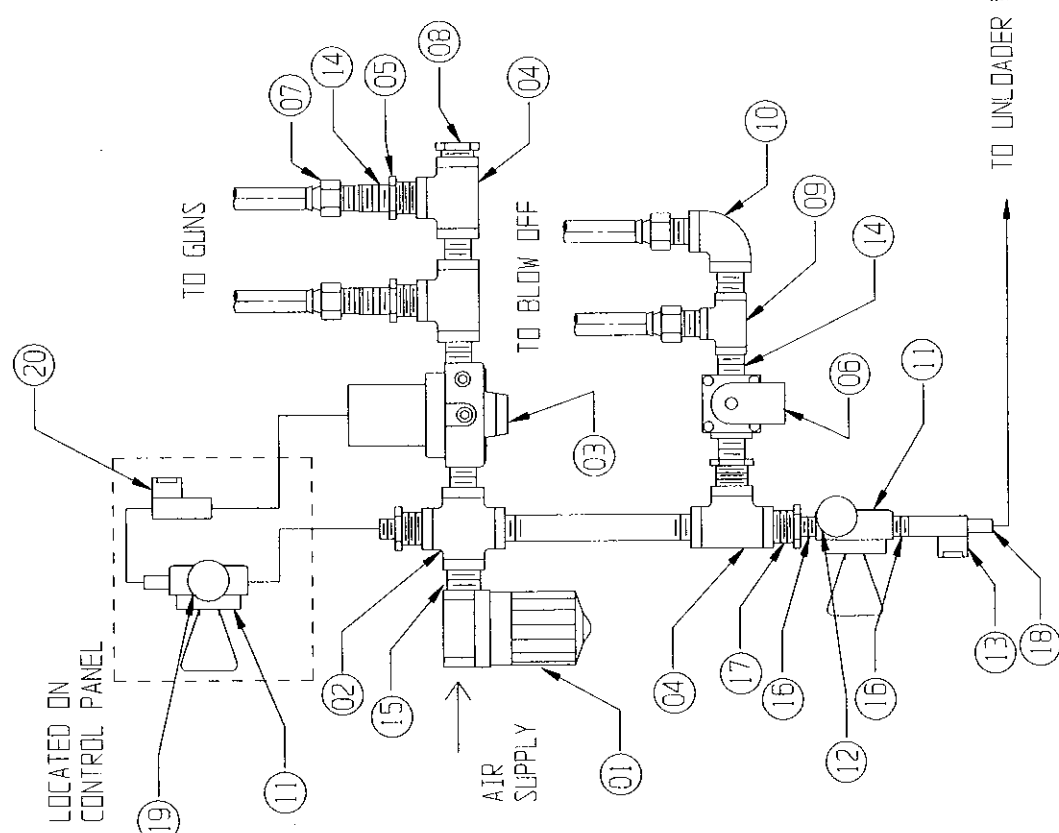

ITEM NO.	QTY.	DESCRIPTION	DWG. NO. / MATERIAL
20	1	1/4" 3 PORT SOLENOID	13-517
19	1	1/8" PRESSURE GAUGE (FLASH)	011363
18	1	TUBE FITTING	
17	1	REDUCER BUSHING, 1" x 1/8"	006252
16	3	1/8" CLOSE NIPPLE	001151
15	4	1" CLOSE NIPPLE	14-357
14	3	1/2" CLOSE NIPPLE	006249
13	1	1/8" SOLENOID	13-516
12	1	1/8" PRESSURE GAUGE	16-920
11	2	1/8" REGULATOR	001564
10	1	1/2" STREET ELBOW	14-372
09	1	1/2" TEE	14-380
08	1	1" PIPE PLUG	14-374
07	4	BARB FITTING 1/2 x 1/2"	14-301
06	1	SOLENOID, 1/2"	13-514
05	3	REDUCER BUSHING, 1" x 1/2"	14-383
04	3	1" TEE	14-359
03	1	REGULATOR, 1", PILOT OPERATED	16-809
02	1	CROSS, 1"	14-422
01	1	FILTER, 1"	16-817

LARRY HESS & ASSOCIATES, INC.  
SALISBURY, NORTH CAROLINA

DESCRIPTION: 2.0 CU. FT. IBS  
AIR CONTROLS UNIVERSAL BIA DESIGN

DATE: 08/09/07  
BY: L.J.F.  
REV. 1

DWG. NO.: B7119

CONFIDENTIAL

THE DISCLOSURE AND CONTENTS OF THIS DRAWING ARE CONFIDENTIAL AND ARE THE EXCLUSIVE PROPERTY OF LARRY HESS & ASSOCIATES, INC. THIS DRAWING IS TO BE REPRODUCED OR TRANSMITTED IN ANY FORM OR BY ANY MEANS WITHOUT THE WRITTEN PERMISSION OF LARRY HESS & ASSOCIATES, INC.

REV.	DESCRIPTION	BY	DATE

A14140-M

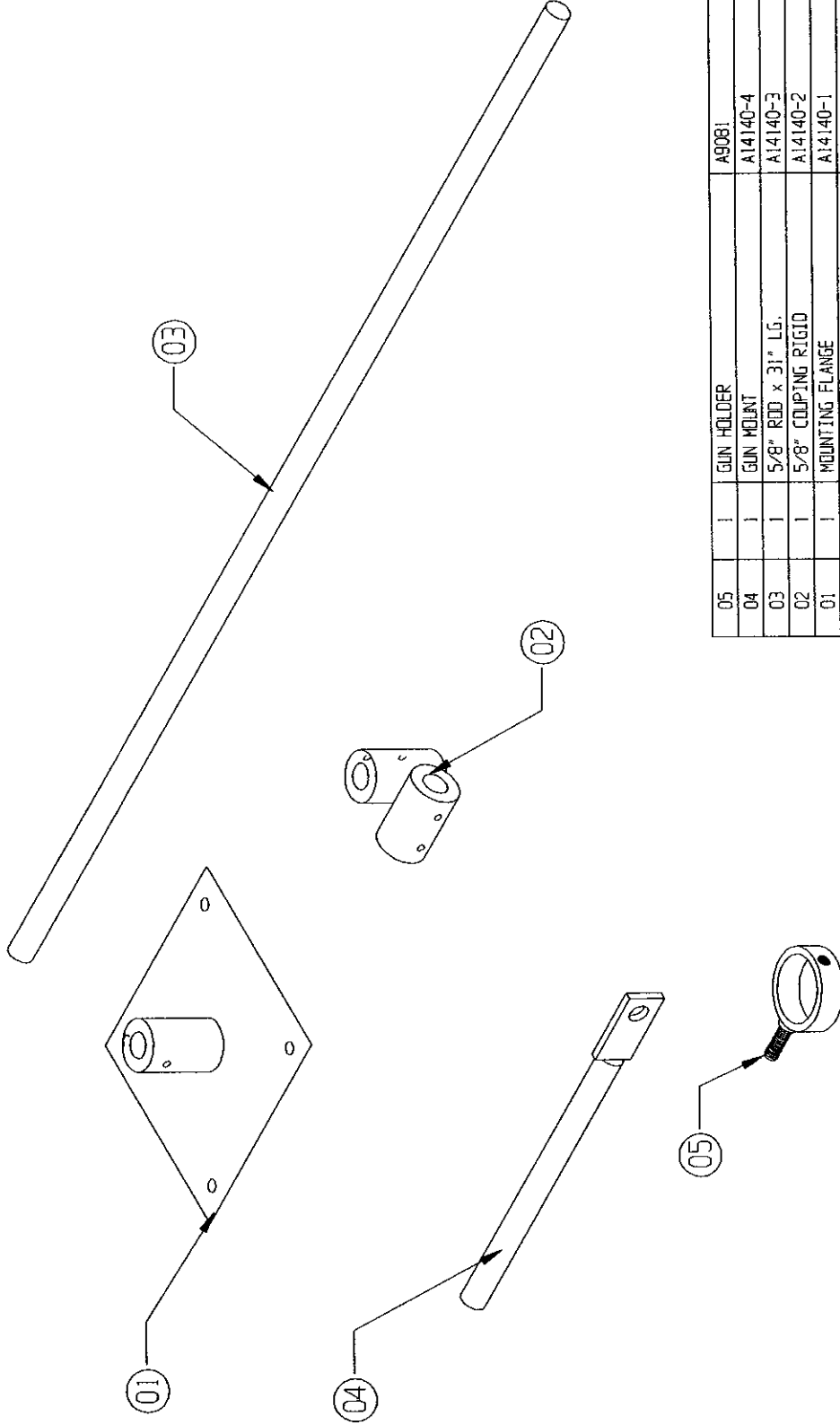

05	1	GUN HOLDER	A9081
04	1	GUN MOUNT	A14140-4
03	1	5/8" ROD x 31" LG.	A14140-3
02	1	5/8" COUPLING RIGID	A14140-2
01	1	MOUNTING FLANGE	A14140-1
ITEM NO.	QTY.	DESCRIPTION	DWG. NO. / MATERIAL

LARRY HESS & ASSOCIATES, INC.  
SALISBURY, NORTH CAROLINA

DESCRIPTION:  
BB-2 GUN MOUNT DETAILS

MATERIAL: PER DWG.  
DRAWING NO.: A14140-M

**CONFIDENTIAL**

THE DISCLOSURES AND CONTENTS OF THIS DRAWING ARE CONFIDENTIAL AND ARE THE EXCLUSIVE PROPERTY OF BLAST-IT-ALL® A DIV. OF LARRY HESS & ASSOCIATES, INC. THIS DRAWING IS NOT TO BE COPIED OR REPRODUCED WHOLLY OR IN PART WITHOUT WRITTEN PERMISSION OF LARRY HESS & ASSOCIATES, INC.

REV.	DESCRIPTION	BY	DATE
1	ADDED ITEM 05	LJF	07/11/01

A9074

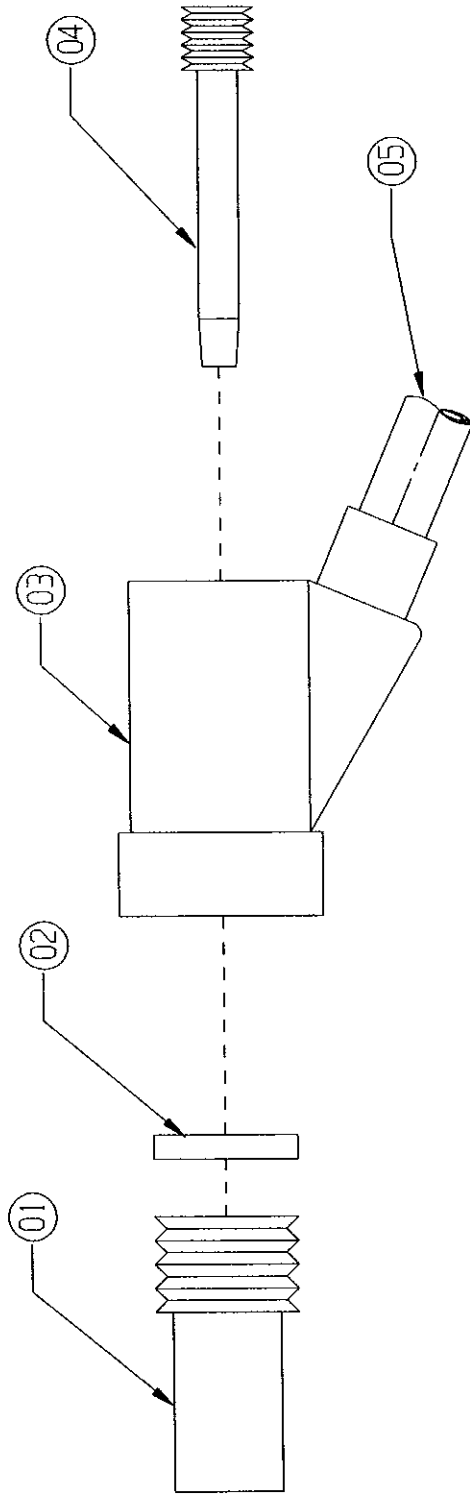

SIZE COMBINATIONS		
NOZZLE	ORIFICE	
1/4"	1/8"	011365
5/16"	5/32"	011366
3/8"	3/16"	011367
1/2"	1/4"	011368

05	1	HOSE 5/8 I.D. x 7/8 O.D.	011370
04	1	ORIFICE	SEE CHART
03	1	GUN BODY	011369
02	1	WASHER	14-113
01	1	NOZZLE	SEE CHART
ITEM NO.	QTY.	DESCRIPTION	DWG. NO. / MATERIAL

LARRY HESS & ASSOCIATES, INC.  
SALISBURY NORTH CAROLINA

DESCRIPTION: BLAST GUNS  
BB-2  
MATERIAL: PER DWG.

DATE:	08/28/00	SCALE:	1/2" = 1"	JOB NO.:	STD.
DRAWN BY:	LJF	DATE:		DATE:	
DWG. BY:		FRACTIONAL:		DECIMAL:	
		ANGULAR:			

REV.	DESCRIPTION	BY	DATE

CONFIDENTIAL

THE DISCLOSURES AND CONTENTS OF THIS DRAWING ARE CONFIDENTIAL AND ARE THE EXCLUSIVE PROPERTY OF BLAST-IT-ALL © A DIV. OF LARRY HESS & ASSOCIATES, INC. THIS DRAWING IS NOT TO BE COPIED OR REPRODUCED WHOLLY OR IN PART WITHOUT WRITTEN PERMISSION OF LARRY HESS & ASSOCIATES, INC.

DRAWING NO.: A9074

B14020

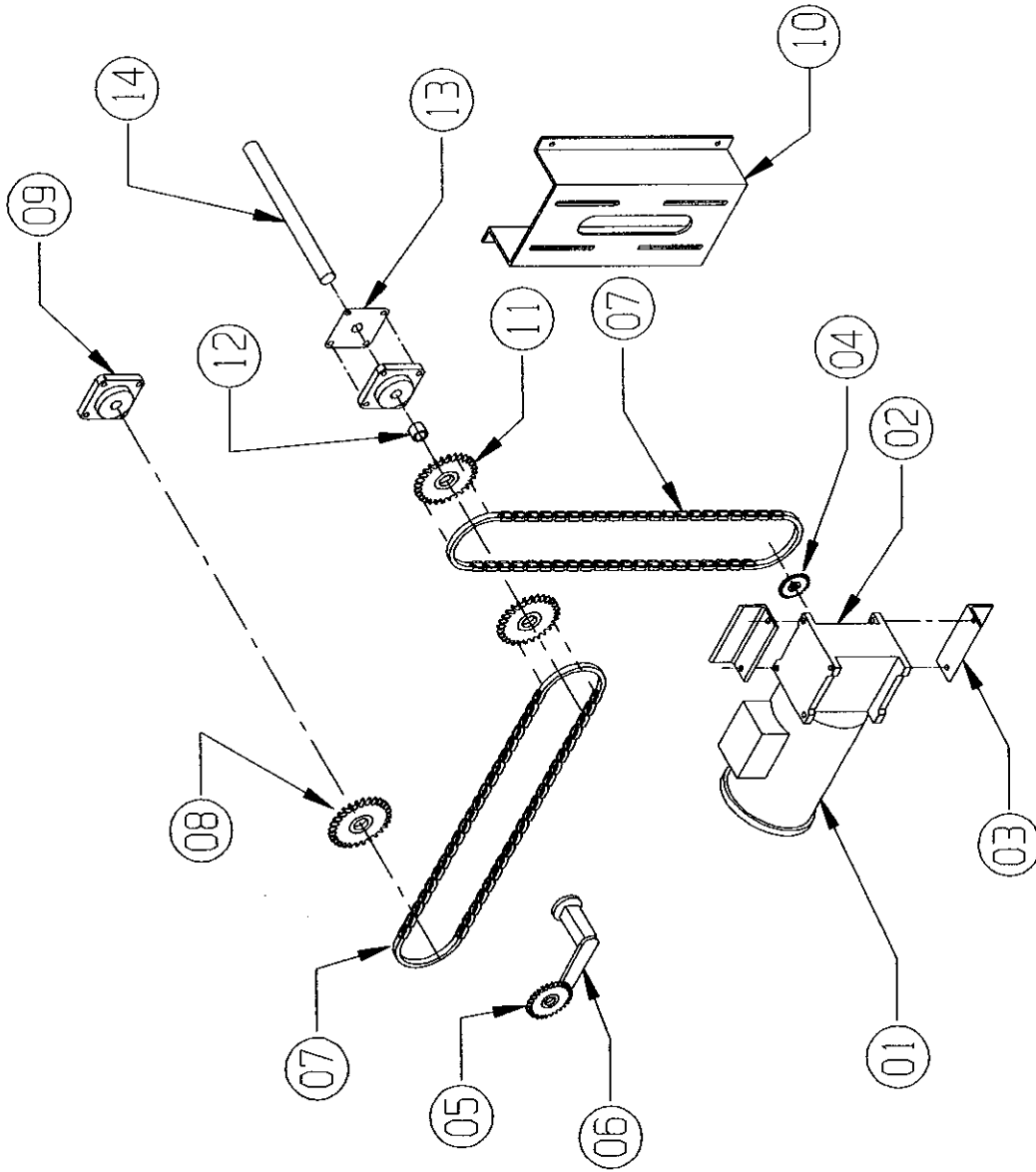

ITEM NO.	QTY.	DESCRIPTION	DWG. NO. / MATERIAL
14	2	SHAFT	A14139
13	4	DUST SEAL	A14143
12	4	SLEEVE 7/8" x 1"	007524
11	1	SPROCKET 30T	011381
10	1	MOTOR SUPPORT PLATE	B14019
9	4	1" x 4 BOLT FLANGE BEARING	15-920
8	2	DRIVEN SPROCKET 18T	011382
7	2	#40 DRIVE CHAIN	15-975
6	1	CHAIN TENSIDNER	010626
5	1	TENSIDNER SPROCKET	010625
4	1	DRIVE SPROCKET Ø 1" 12T	010784
3	2	GEAR REDUCER BRACKETS	A14137
2	1	50:1 GEAR REDUCER	15-987
1	4	1/2 HP 1750 RPM MOTOR (D.C.)	000088

LARRY HESS & ASSOCIATES, INC.  
 SALISBURY, NORTH CAROLINA

DESCRIPTION: 2.0 CU. FT. DRIVE ASM.  
 MATERIAL:  
 UNIVERSAL- B1A

DATE: 05/31/00  
 DRAWING NO.: B14020

**CONFIDENTIAL**

THE DISCLOSURES AND COMMENTS OF THIS DRAWING ARE CONFIDENTIAL AND ARE THE EXCLUSIVE PROPERTY OF BLAST-IT-ALL (an) A DIV. OF LARRY HESS & ASSOCIATES, INC. THIS DRAWING IS NOT TO BE COPIED OR REPRODUCED WHOLLY OR IN PART WITHOUT WRITTEN PERMISSION OF LARRY HESS & ASSOCIATES, INC.

REV.	DESCRIPTION	DATE	BY
3	CHANGED PT. # 12 TO 04	3/27/07	L.F.
2	CHANGED MOTOR MOUNT STYLE	9/28/00	L.F.
1	ADDED PT. #'S	9/25/00	L.F.

A14138-M

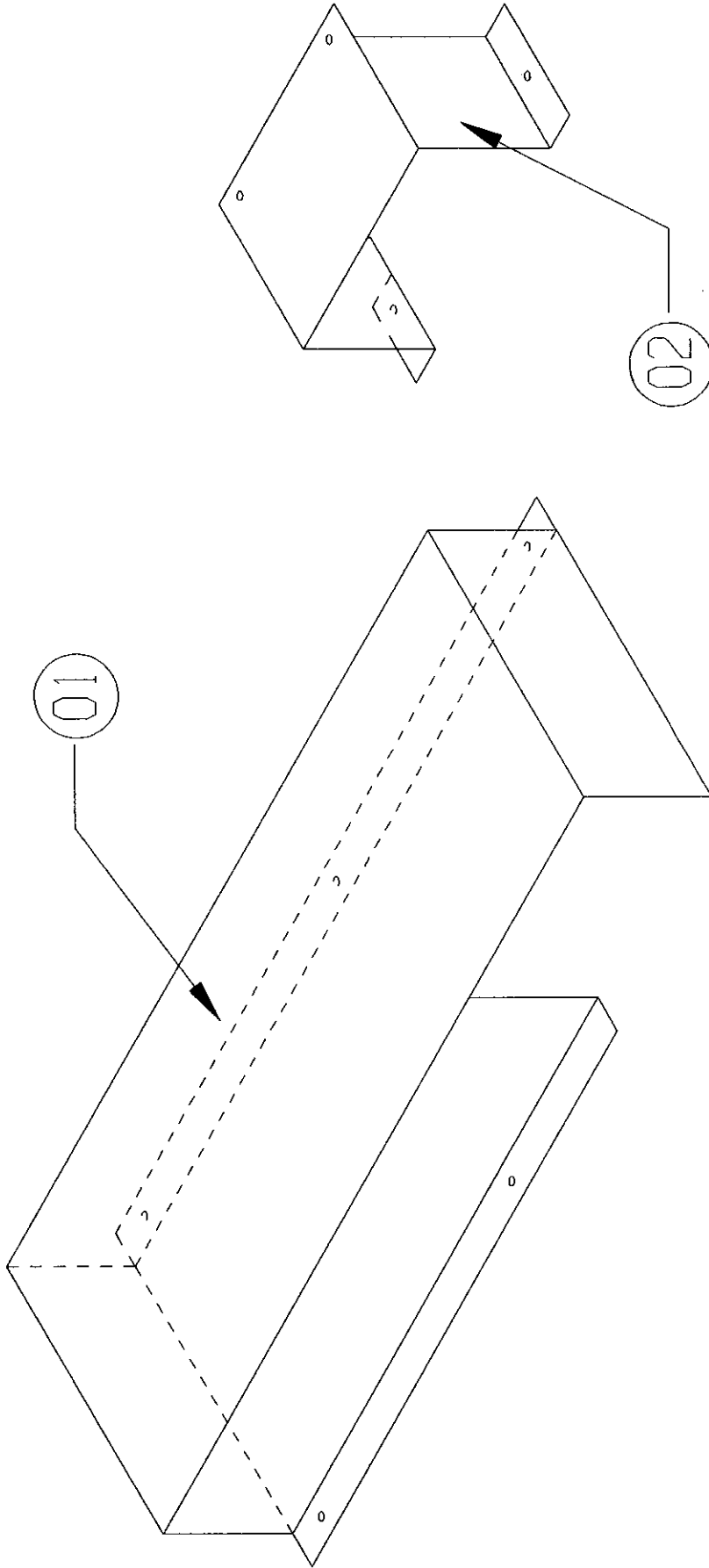

LARRY HESS & ASSOCIATES, INC.  
SALISBURY, NORTH CAROLINA

DESCRIPTION: GEAR & SPROCKET COVER DETAILS  
MATERIAL: PER DWG.

DRAWING NO.: A14138-M  
DATE: 08/28/00  
SCALE: 3/16" = 1"  
JOB NO.:  
NEXT ASY.:

REV.	DESCRIPTION	BY	DATE

**CONFIDENTIAL**  
THE DISCLOSURES AND CONTENTS OF THIS DRAWING ARE CONFIDENTIAL AND ARE THE EXCLUSIVE PROPERTY OF BLAST-IT-ALL @ A DIV. OF LARRY HESS & ASSOCIATES, INC. THIS DRAWING IS NOT TO BE COPIED OR REPRODUCED WHOLLY OR IN PART WITHOUT WRITTEN PERMISSION OF LARRY HESS & ASSOCIATES, INC.



ENGINEER  
DEC  
DWG. NO. M1118

DATE  
06/15/06

DESCRIPTION  
700 RECLAIMER WITH REMOVEABLE TOP

LARRY HESS & ASSOCIATES

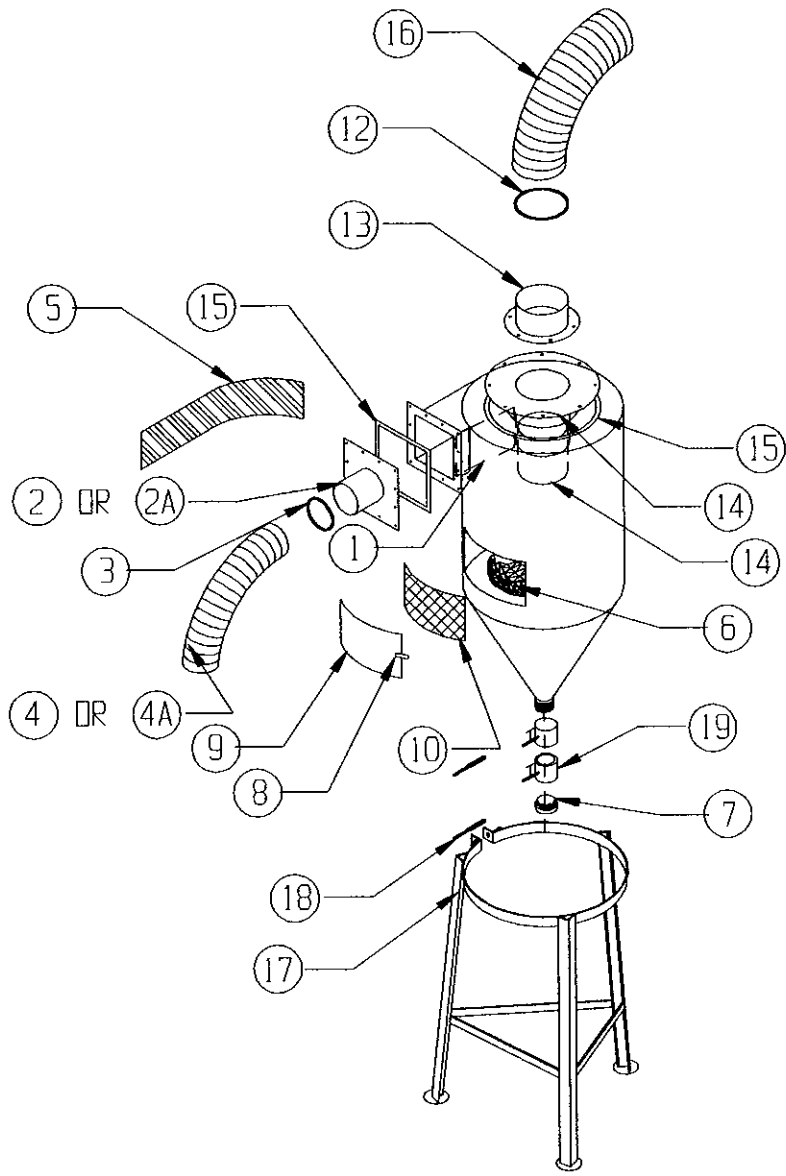

ITEM NO.	700 CFM	DESCRIPTION
1	11-728	BAFFLE
2	11-705	INLET ADAPTOR (5A) 5" Ø INLET ADAPTOR 11-905
3	21-034	CLAMP
4	19-092	FLEX HOSE 4" (SPECIFY LENGTH) (4A) FLEX HOSE 5" 19-094
5	11-717	INLET WEAR PLATE (OPTIONAL)
6	11-706	STD. SCREEN BASKET
6	11-729	BASKET, HEAVY DUTY
7	20-201	DRAIN PLUG
8	15-728	DOOR LATCH & CATCH ASMB.
9	11-702	DOOR AND GASKET
10	11-703	GASKET (ONLY)
11	11-701	RECLAIMER HOUSING
12	21-036	CLAMP
13	002028	TOP OUTLET (USED WITH DUST COLLECTOR)
14	11-731	INNER VACUUM TUBE WITH SLIDE TUBE
15	24-030	PUTTY TAPE
16	19-096	FLEX HOSE, 6" TO DUST COLLECTOR (USE WITH #13)
17	A1197	TRIPOD STAND (700)
18	14-301	FITTING, 1/2 x 1/2
19	20-200	MEDIA VALVE, 2"

B2129

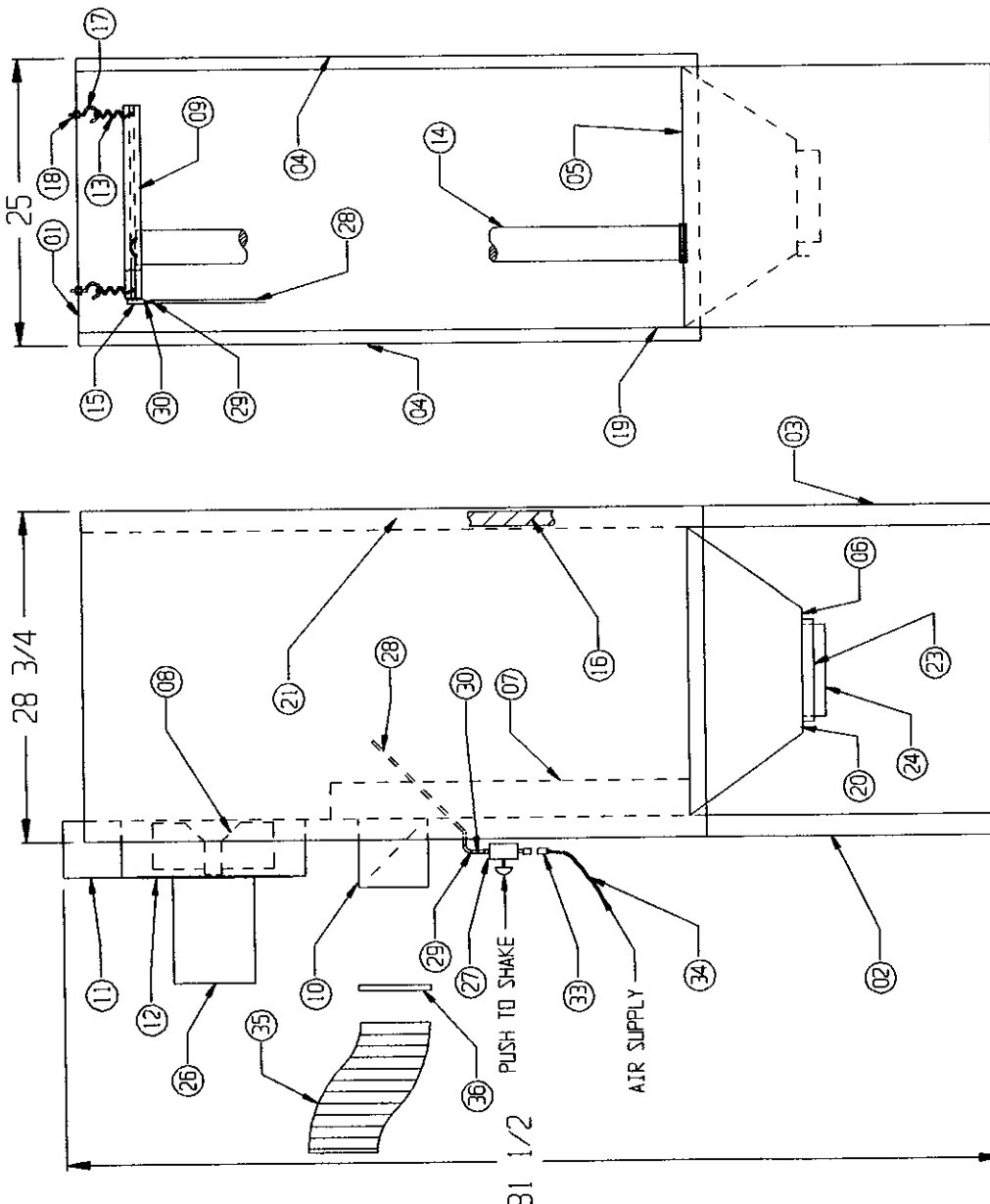

ITEM NO.	QTY.	DESCRIPTION	ENG. NO. / MATERIAL
38			
37			
2		SCREW CLAMP	21-036
5		FLEX HOSE (6')	19-096
6		1/4" PLASTIC HOSE	18-111
33	1	MALE CONNECTOR	16-951
32			
31			
30	2	1/8" x 1/4" HOSE BARB	14-316
29	2	1/4" SCREW CLAMPS	000496
28	3	1/4" AIR HOSE	18-074
27	1	SHAKER VALVE 1/8"	16-830
26	1	MOTOR 1HP-110V 50C	13-700
25			
24	1	OUTLET FLANGE 8" DIA.	000725
23	1	SLIDE GATE	000324
22			
21	6	1/4" WING NUT	000305
20	80	1/4" x 3/4" LG. ROLLIX	000301
19	12	1/4" x 1" LG. ROLLIX	000377
18	8	3/16" HEX NUT	000378
17	4	3/16" EYE BOLT	000379
16	50	1/2" x 1" GASKET	24-054
15	1	SHAKER	16-919
14	25	DUST BAG	11-349
13	4	SPRING	15-721
12	1	BLOWER/MOTOR PLATE	11-720
11	1	BLOWER HOUSING ASS'Y.	11-716
10	1	INLET DAMPER ASS'Y. (6" DIA.)	000723
09	1	DUST BAG MOUNT ASS'Y.	A2501
08	1	BLADE ASS'Y.	11-718
07	1	0-10 PLENUM ASS'Y.	000335
06	1	SPACER	000329
05	1	SUMP ASS'Y.	A2500
04	2	DOOR PANEL	A2466
03	1	RIGHT SIDE PANEL	A2465-1
02	1	LEFT SIDE PANEL	A2464-1
01	1	TOP PLATE	A2467-1

LARRY HESS & ASSOCIATES, INC.  
 SALISBURY, NORTH CAROLINA

DESCRIPTION: 700 CFM  
 0-10 DUST COLLECTOR ASS'Y.

MATERIAL: PER DWG.

DATE: 02/10/96  
 DESIGNED BY: JMS  
 DRAWING NO.: B2129

DWG. NO. M2079

ENGINEER DEC

DATE 04/30/02

DESCRIPTION M2 DUST COLLECTOR WITH LEGS

LARRY HESS & ASSOCIATES

700 CFM

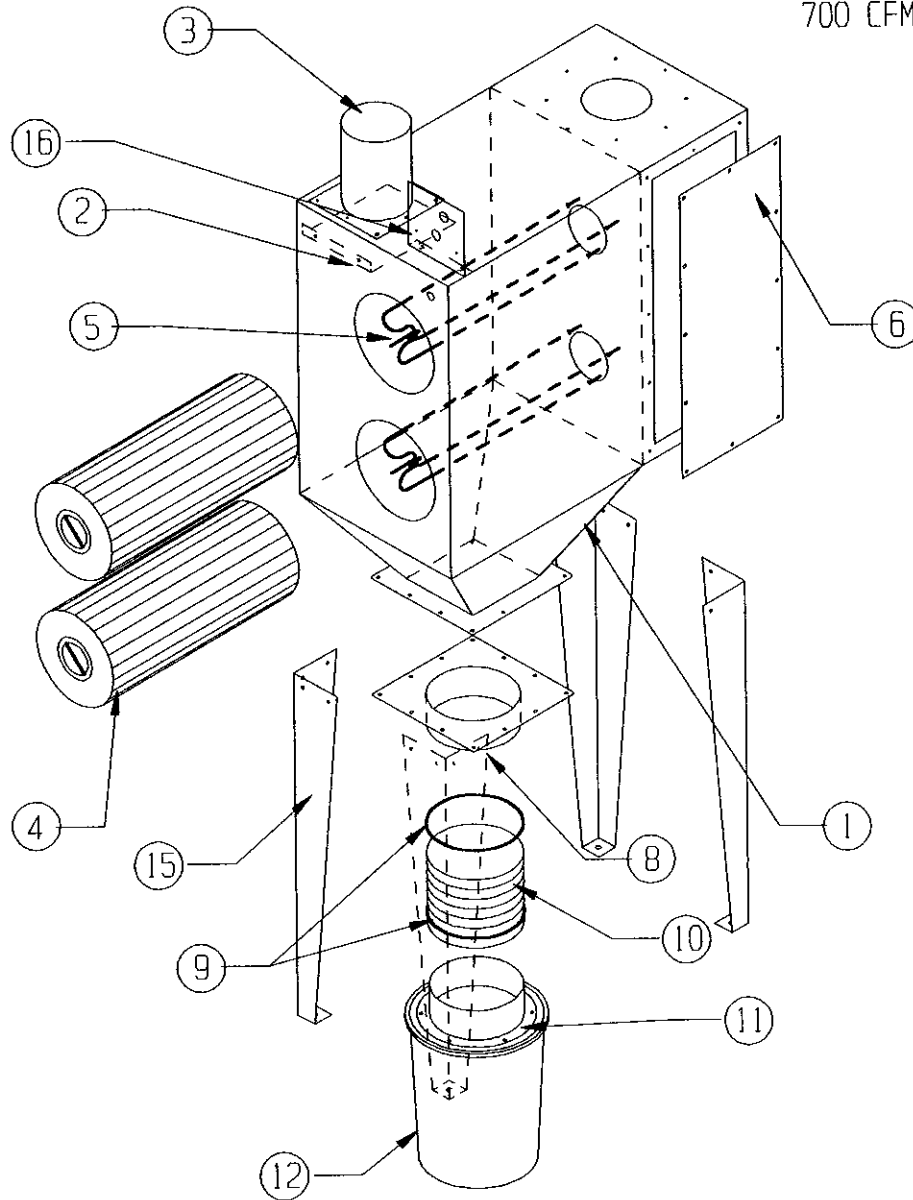

ITEM NO.	PART NO.	DESCRIPTION
1	B2198	DUST COLLECTOR
2	B2198-9	BAFFLE PLATE
3	000723	DAMPER INLET
4	011519	CARTRIDGE
5	011520	CARTRIDGE HOLDER
6	B2198-8A	COVER PLATE RIGHT SIDE
7	-----	-----
8	B2198-10	WASTE OUTLET
9	21-038	CLAMP
10	19-098	FLEX HOSE 8" $\phi$ x 12" LG.
11	011523	PAIL COVER
12	011522	5 GALLON PAIL
13	-----	-----
14	-----	-----
15	A2628	LEGS (4)
16	A741	MAGNEHELIC GAGE BRACKET

M12041

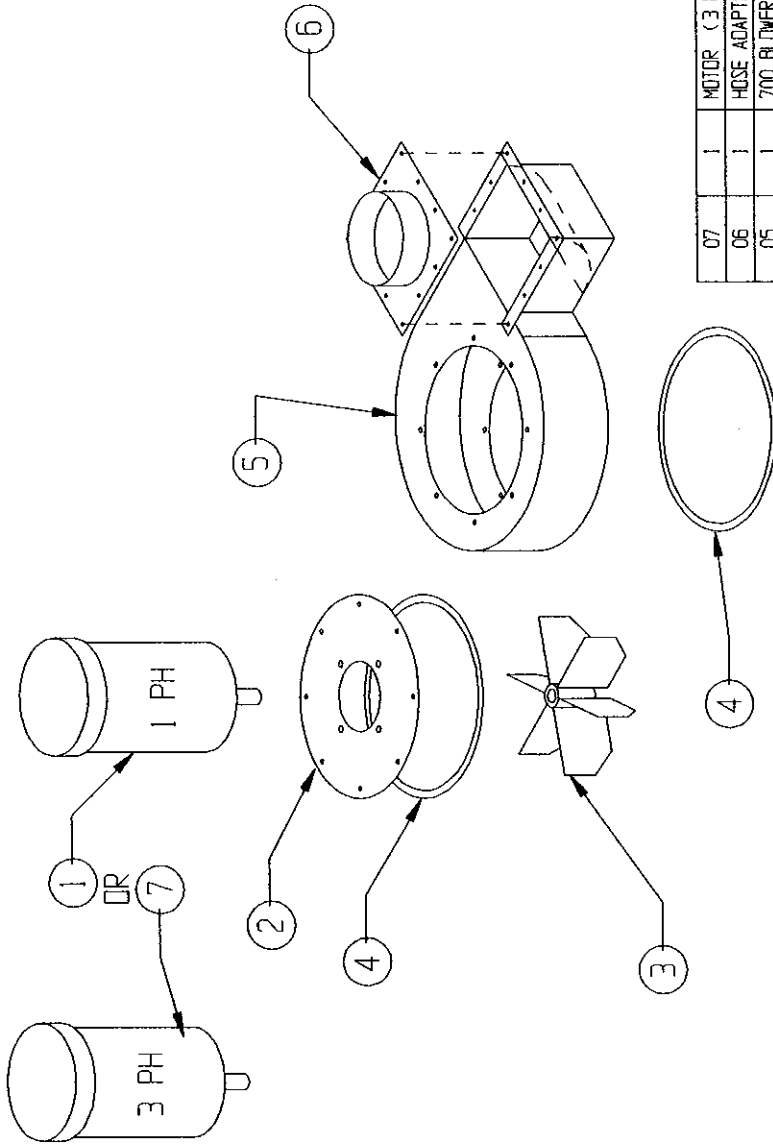

07	1	MOTOR (3 PHASE)	13-701
06	1	HOSE ADAPTER	A12767-2
05	1	700 BLOWER HOUSING UPWARD	11-716-UP
04	*	PUTTY TAPE	24-030
03	1	BLADE	11-718
02	1	MOTOR PLATE	11-720
01	1	MOTOR (1 PHASE)	13-700
ITEM NO.	QTY.	DESCRIPTION	DWG. NO. / MATERIAL

LARRY HESS & ASSOCIATES, INC.  
SALISBURY, NORTH CAROLINA

DESCRIPTION: 700 REPLACEMENT BLOWER PARTS  
MATERIAL: PER DWG.

DATE:	05/03/02	SCALE:	NONE	JOB NO.:	
DEC:		FRACTIONAL:		REV. ASS'Y.:	
DATE:		DECIMAL:		DRAWING NO.:	M12041
DATE:		INCHES:			

CONFIDENTIAL

THE DISCLOSURES AND CONTENTS OF THIS DRAWING ARE CONFIDENTIAL AND ARE THE EXCLUSIVE PROPERTY OF BLAST-IT-ALL, A DIV. OF LARRY HESS & ASSOCIATES, INC. THIS DRAWING IS NOT TO BE COPIED OR REPRODUCED WHOLLY OR IN PART WITHOUT WRITTEN PERMISSION OF LARRY HESS & ASSOCIATES, INC.

REV.	DESCRIPTION	BY	DATE

B5218

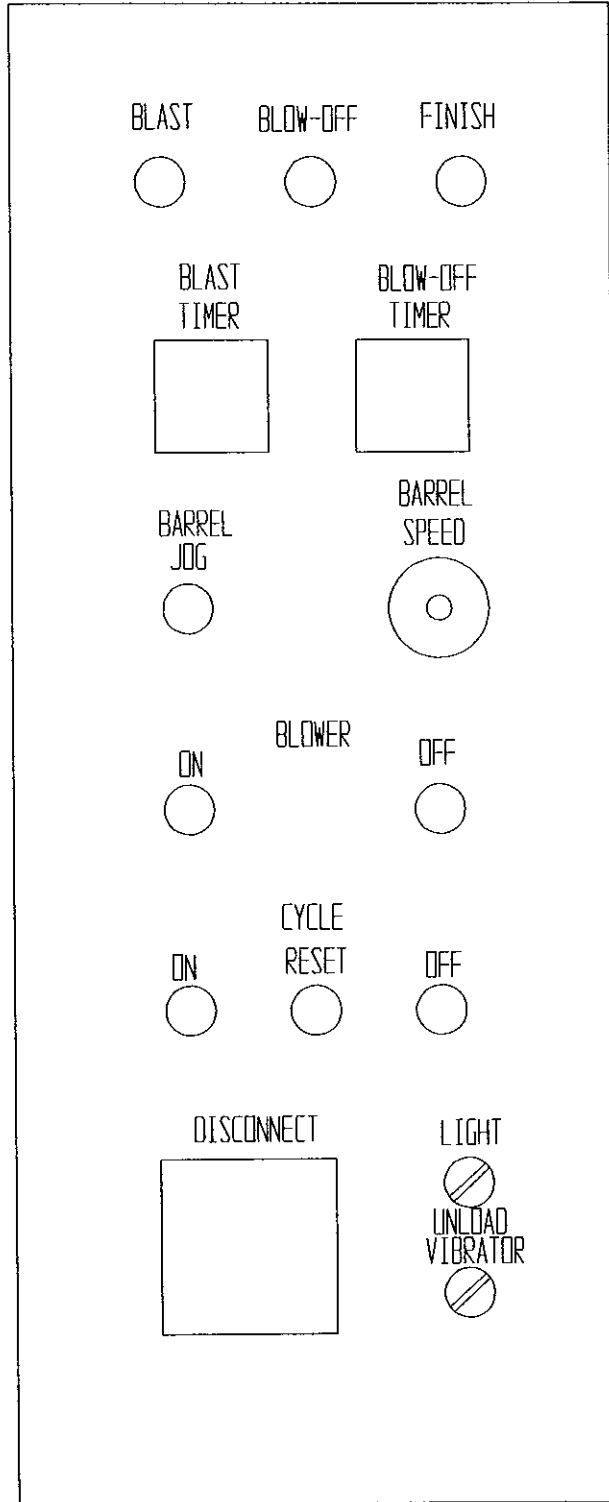

LARRY HESS & ASSOCIATES, INC.  
 SALISBURY, NORTH CAROLINA

DESCRIPTION: BB-2R ELE. BOX  
 MATERIAL:

DATE: L.F. 06/30/06  
 TIME: 11:00  
 DRAWING NO.: B5218

**CONFIDENTIAL**

THE DIMENSIONS AND CONTENTS OF THIS DRAWING ARE CONFIDENTIAL AND ARE THE EXCLUSIVE PROPERTY OF LARRY HESS & ASSOCIATES, INC. THIS DRAWING IS NOT TO BE COPIED OR REPRODUCED WHOLLY OR IN PART WITHOUT WRITTEN PERMISSION OF LARRY HESS & ASSOCIATES, INC.

REV.	DESCRIPTION	BY	DATE

B5219

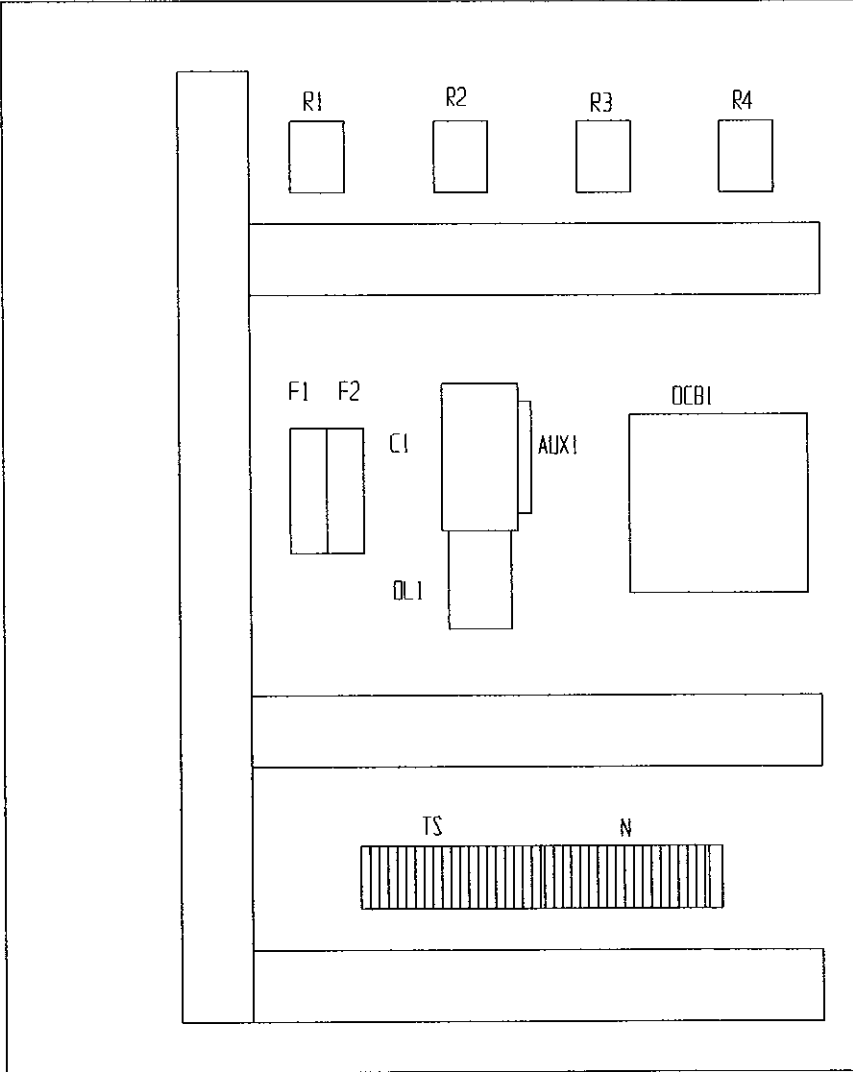

LARRY HESS & ASSOCIATES, INC.  
SALTSBURY, NORTH CAROLINA

DESCRIPTION: BB-2R PANEL LAYOUT MATERIAL:

DATE: 06/30/06  
BY: L.F.  
SCALE: NTS  
DRAWING NO.: B5219

**CONFIDENTIAL**

THE DESCRIPTIONS AND CONTENTS OF THIS DRAWING ARE  
CONFIDENTIAL AND ARE THE EXCLUSIVE PROPERTY OF  
LARRY HESS & ASSOCIATES, INC.  
THIS DRAWING IS NOT TO BE COPIED OR REPRODUCED WHOLLY  
OR IN PART WITHOUT WRITTEN PERMISSION OF  
LARRY HESS & ASSOCIATES, INC.

REV.	DESCRIPTION	BY	DATE



	BACK PANEL	010880-8 BP
	ENCLOSURE- 30 x 24 x 12	010880-12
TMR2	TIMER, BLOW OFF TIME	011848
TMR1	TIMER, BLAST TIME	011848
SW2	SELECTOR SW, UNLOAD VIBRATOR	010673
SW1	SELECTOR SWITCH, LIGHTS	010673
SOL3	SOLENOID, BLOW OFF	13-514
SOL2	SOLENOID, BLAST	13-514
SOL1	SOLENOID, 2 PORT, UNLOAD VIBRATOR	13-514
SOS1	SWITCH, SAFETY DOOR	010584
R4	RELAY, DC DRIVE	16-635
R3	RELAY, FINISH	13-635
R2	RELAY, BLOW OFF START	13-635
R1	RELAY, CYCLE START	13-635
POT-1	POTENTIOMETER, SPEED CONTROL, BARREL	
PL3	PILOT LIGHT, CYCLE FINISHED, RED	011617
PL2	PILOT LIGHT, BLOW OFF, GREEN	011619
PL1	PILOT LIGHT, BLAST, AMBER	011618
PB6	PUSHBUTTON, YELLOW, BARREL JOG	011841
PB5	PUSHBUTTON, BLACK, CYCLE RESET	011842
PB4	PUSHBUTTON, GREEN, CYCLE START	010675
PB3	PUSHBUTTON, RED, CYCLE STOP	010674
PB2	PUSHBUTTON, GREEN, MOTOR START	010675
PB1	PUSHBUTTON, RED, MOTOR STOP	010674
OL1	OVERLOAD RELAY	011772
M2	MOTOR, DC, BARREL ROTATION	000088
M1	MOTOR, BLOWER	13-700
FB2	FUSE BLOCK	011722
FB1	FUSE BLOCK	011722
F2	FUSE, 9 A.	13-6309
F1	FUSE, 15 A.	13-63015
DISC1	DISCONNECT	011846
DCB1	DC DRIVE BOARD	13-108-1
C1	STARTER	011665
BASE	RELAY BASE, 11 PIN	13-636
AUX2	AUX CONTACTS, 2 NO OPS POWER	011720
AUX1	AUX CONTACTS, 2 NO, HOLD IN	011720
ITEM	DESCRIPTION	DWG. NO. / MATERIAL
LARRY HESS & ASSOCIATES, INC. SALISBURY, NORTH CAROLINA		
DESCRIPTION: BB-2R ELE. BOM		MATERIAL:
DRAWN BY: LJF	DATE: 6/30/06	SCALE:
ENG'D BY:	DATE:	ANGULAR:
JOB NO: 44351	SCALE:	DRAWING NO.:
FRAC TIONAL: DECIMAL:	NEXT ASS'Y:	B5217-1



# SIMIREL

## Time relay for plug-in socket

7PV3

DIN VDE 0660, IEC 60947

Operating Instructions

Order No.: 7ZX1012-0PV34-1AA1

English

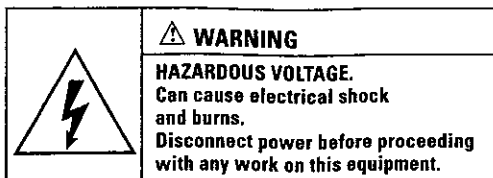

Reliable functioning of the equipment is only ensured with certified components.

### General description

- Functions: A, b, C, d, di, H
- 11 timing ranges: 99.99 s; 999.9 s; 9999 s; 99 min 59 s; 99.99 min; 999.9 min; 9999 min; 99 h 59 min; 99.99 h; 999.9 h; 9999 h
- (Note: the 99.99 s range is inhibited for the d and di intermittent modes)
- Simultaneous and constant display of the current value and pre-selection value (internal battery, minimum life span 10 years at 20 °C)
- Up count (Up) or down count (Down) display
- Contact input
- 8 A/250 V AC relay output (10 A UL)
- Power supply: 24 V AC/DC / 110 V AC bis 240 V AC (tolerance +10 % - 15 %)
- Front panel protection rating IP65

### Readout legends (see fig. I)

- 1 Power supply symbol
- 2 Closed control contact symbol
- 3 Flashing symbol during time delay
- 4 Current value readout (4 digits)
- 5 Unit of time
- 6 Setting the decimo separator
- 7 Operating modes
- 8 Increasing (Up) or decreasing (Down) mode
- 9 Time range
- 10 Changeover relay status symbol  
(NC = Normally Closed, NO = Normally Opened)
- 11 Next stage
- 12 Configuration validation
- 13 Incrementation of time T
- 14 Display of time pre-selection T (4 digits)

### Operating modes (see Fig. III for function diagrams)

- Function A: ON-delay  
Function b: Pulse-shaping  
Function C: OFF-delay  
Function H: Passing make contact  
Function d: Flasher; repeat cycle; starting with interval  
Function di: Flasher; repeat cycle; starting with pulse

### Programming (see fig. IV)

- To program, simply set the switch on the side of the unit to the ON position.
- If the timer has started running, the time delay values:
  - are taken into account immediately if your display is on the up count (Up) and if the new value is greater than the time that has already elapsed,
  - will be taken into account in the next cycle if you are on a down count display (down)
- The unit is supplied with the following configuration: 01.00 s, d (down), C (mode), Prog = ON
- If, inadvertently, you enter the unit test procedure with the entire screen or certain segments of the screen flashing, press the MODE push-button until Bp is obtained on the screen, then press VALID to return to normal operation.
- Incrementation of value T by pressing one of the 4 keys ⊕ corresponding to each digit.

### Utilization precautions

- The power cables and input circuits must be separate.
- A minimum requirement for ventilation and protection from vibration must be provided.



### ATTENTION

This equipment contains a lithium battery, do not incinerate the unit.

### Dimensions and assembly (see fig. V)

- A Panel cut out
- 15 Seal
- 16 Positioning screw
- 17 Frame for panel-mounting
- 18 Panel thickness 1 to 3.5 mm

### Wiring-Diagram (see fig. II and VI)

### Accessories

- 11 pole plug-in socket for standard mounting rail  
LZX: MT78750
- 11 pole plug-in socket with rear connection 7PX9921

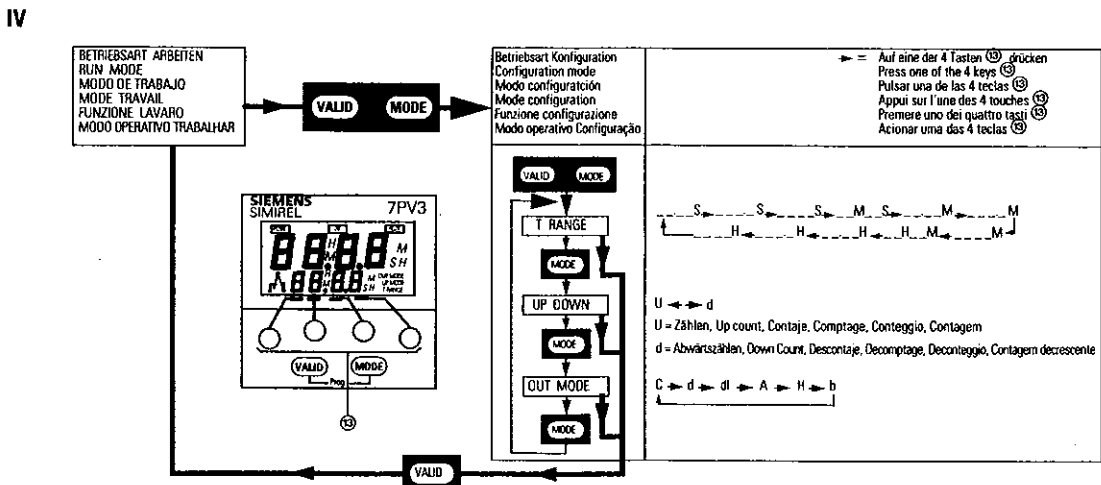
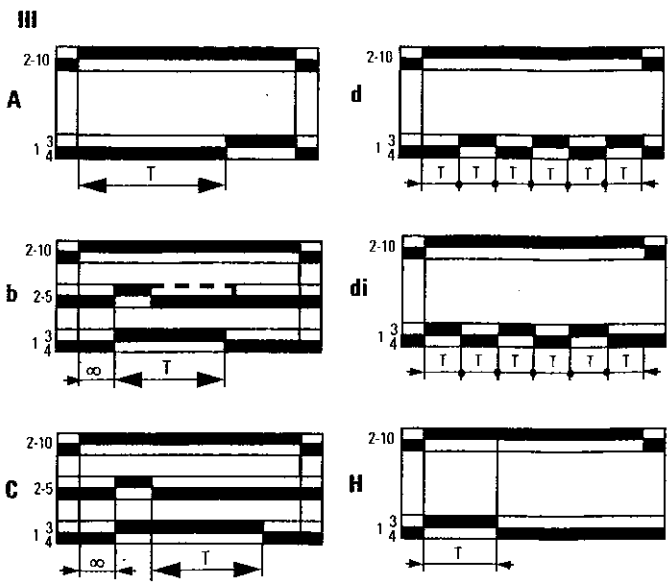
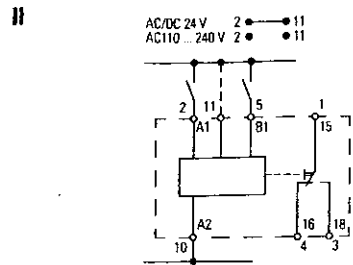
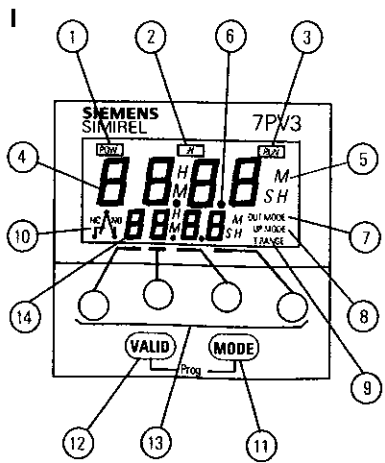

V

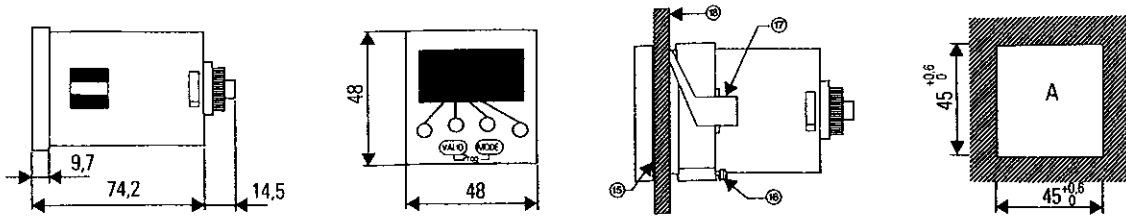

VI

11 Kontakte, 11 pins, 11 contactos  
11 broches, 11 spine, 11 contatos

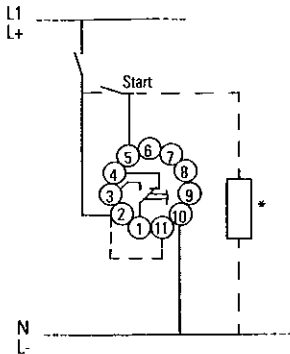

- \* Möglichkeit eine Last zu schalten
- \* Possibility to connect a load
- \* Posibilidad de conectar una carga
- \* Possibilit  de connecter une charge
- \* Possibilit  di collegare una carica
- \* Possibilitade de executar o chaveamento de uma carga

Modell Model Modelo Mod�le Modello Modelo	Spannung Voltage Tensi�n Tension Tensione Tens�o	Anschluss Connection Conexi�n Branchement Allacciamento Conex�o		
		<b>2</b>	<b>11</b>	<b>10</b>
24 V AC/DC	24 V AC/DC	+ ●	●	- ●
110 ... 240 V AC	110 ... 240 V AC	●		●
7PV3348-2AX34				

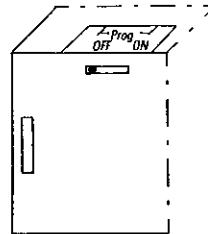

- OFF = Programmierung blockiert
- OFF = Programming inhibited
- OFF = Programacion inhibida
- OFF = Programmation inhib e
- OFF = Programmazione disabilitata
- OFF = Programac o bloqueada

**Technical Assistance:** Telephone: +49 (0) 9131-7-43833 (8<sup>00</sup> - 17<sup>00</sup> CET)  
E-mail: [technical-assistance@siemens.com](mailto:technical-assistance@siemens.com)  
Internet: [www.siemens.de/lowvoltage/technical-assistance](http://www.siemens.de/lowvoltage/technical-assistance)

Fax: +49 (0) 9131-7-42899

**Technical Support:** Telephone: +49 (0) 180 50 50 222

Technische  nderungen vorbehalten. Zum sp teren Gebrauch aufbewahren!  
Subject to change without prior notice. Store for use at a later date.  
© Siemens AG 2000

**Bestell-Nr./Order No.:** 7ZX1012-0PV34-1AA1  
Printed in the Federal Republic of Germany

## WARRANTY

Larry Hess & Associates, Inc. Warrants to the original purchaser the merchandise sold to be free from defects in material and workmanship under normal use and service for a period of one (1) year. Upon prompt notification by the buyer, to LHA, components that are determined by LHA to be defective will be repaired or replaced at no additional charge, F.O.B. our factory.

Manufacturer shall have the right to inspect prior to replacing all merchandise in question.

This warranty does not apply to parts that are directly involved in the blasting operation. Example: gun, gun parts, viewing window, hose, gloves, etc.

Manufacturer shall not be required to pay any removal or installation charges whatsoever under this warranty.

Manufacturer shall not be liable for prospective profits, special or consequential damages, nor shall any recovery of any kind against manufacturer be greater in amount than the cost of repairs of defects in workmanship.

This warranty does not apply to damage caused by accidents, damage in transit, alterations by unauthorized personnel, abuse or damage by flood, fire, or acts of God, nor by artificially generated electric currents or any other cause whatsoever except defects in material or factory workmanship.

In all cases, defective parts must be returned to Larry Hess & Associates, Inc. before credit is issued.

If genuine BLAST-IT-ALL® replacement parts are not used, the warranty is void.

This warranty is in lieu of all other warranties expressed or implied and releases Larry Hess & Associates, Inc. of all other obligations and liabilities whatsoever. This warranty neither assumes nor authorizes any person to assume any obligation other than those specified by this warranty.

## WARNING

**DO NOT USE SAND. SAND WILL CAUSE SILICA DUST, WHICH IS THE CAUSE OF SILICOSIS DISEASE, A CONDITION OF MASSIVE FIBROSIS OF THE LUNGS. THIS STATEMENT INDICATES POTENTIAL PERSONNEL HAZARD. FAILURE TO COMPLY WITH THESE INSTRUCTIONS MAY RESULT IN PERSONAL INJURY.**

BLAST-IT-ALL®  
Larry Hess & Associates, Inc.  
Airport Industrial Park  
185 Piper Lane  
P.O. Box 1615  
Salisbury, NC 28145-1615