



Shown With Optional DC

ECO 3624

The ECO line of equipment was designed for the hobbyist or very light production use. The ECO is constructed from heavy gauge metal, which is continuously welded. Also incorporated into the line are several products from the BLAST-IT-ALL[®] production blasting equipment, proven reliability such as the blast gun. The ECO is also designed for a small company to start blasting with only a dust collector; then, without a lot of expense enables that user to convert to a reclamation system with the ECO Reclaimer Kit.

While, the ECO is limited to specifically smaller sizes than production type equipment, but it is considered the highest caliber blaster manufactured today.



BLAST-IT-ALL[®]
Salisbury, NC 28145
(800) 535-2612
www.blast-it-all.com
sales@blast-it-all.com



ECO 3624

SHOWN WITH

Optional Dust Collector:
Single cartridge with 100 CFM fan

Light:

Top mounted 120 volt flood

Viewing Window:

Large 12"x20" tempered glass provides long life
and minimizes static build up of dust.

Mylar Dispenser

Doors:

Two, one front lift hatch, and one
Side service

Glove Arm Hole: Heavy duty cloth lined vinyl snap-in
gloves are quick changing

Clean out:

Bottom 2" sump plug

Media gun:

Standard, hand trigger
Either 12 or 21 CFM

Media feed:

Inside media pick up tube

Media Hose:

½" Media feet tube to gun

Machine Construction: Heavy 14 gauge
welded steel construction. Two coats of
industrial quality paint.

Packing: Machine secured on wood
pallet, dust collector (optional) packed under
cabinet on same skid.

Compressed air inlet:

Left side / ½"

Motor:

With optional DC
100 CFM vacuum motor
120 Volts

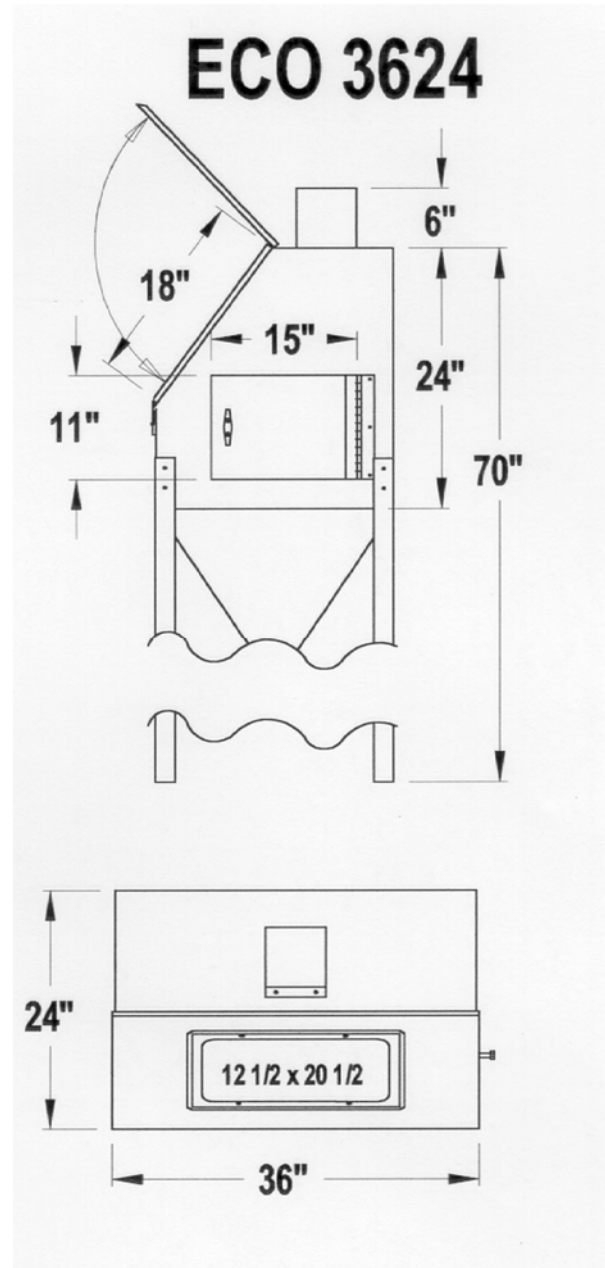

Machine Options:
Mylar dispenser
ECO Cartridge Dust collector
300 CFM reclaim