



LB4024-3

The LITTLE-BLASTER equipment was designed for the hobbyist or very light production use. The LITTLE-BLASTER is constructed from heavy gauge metal, which is continuously welded. Also incorporated into the line are several products from the BLAST-IT-ALL[®] production blasting equipment, proven reliability such as the blast gun. The LITTLE-BLASTER is also designed for a small company to start blasting without a lot of expense.

While, the LITTLE-BLASTER is limited to specifically smaller sizes than production type equipment, but it is considered the highest caliber blaster manufactured today.



BLAST-IT-ALL[®]
Salisbury, NC 28145
(800) 535-2612
www.blast-it-all.com
sales@blast-it-all.com



Includes:

Reclaimer: High performance 300 CFM cyclone type reclaimer.

Light Box: Two (2) tube 24" fluorescent light, for best possible lighting in blast chamber, On-Off control switch for light and reclaimer.

Viewing Window: Large 12"X20" tempered glass provides long life and minimizes static build up of dust.

Door Latch: Heavy-duty cam type, adjustable for positive door seal.

Glove Arm Hole: Heavy duty cloth lined vinyl snap-in gloves are quick changing.

Air Flow Regulator and Gauge: Allows adjustable air pressure to gun for proper media flow to provide finish desired.

Clean out door: Easy access to filter screen, trapping heavy particles from abrasives. Allows recovery of small parts that may fall from blast chamber.

Safety Foot Control: Prevents accidental blast operation.

Doors: Large double walled doors (both sides) for opening size see figure "C". Knife sealing edge assures positive seal in blast chamber.

Motor: 1/2 HP, 120 volts, 11 amp, 3450 rpm switch controlled.

Dust Collector: Cotton sateen dust bag collects dust from reclaimer. Zipper in bottom for emptying dust and debris.

Fill Door: To add media to machine and remove debris from debris screen basket inside reclaimer, adjustable air intake on door.

Sump Hose: 4" flexible duct hose, from machine sump outlet to reclaimer inlet.

Media Valve: Universal Feed allowing all types of abrasives to be used. 2" plug outlet for easy clean-out.

Media Hose: 1/2" media line hose from reclaimer media valve to bottom fitting on blast gun.

Compressed Air Inlet: 1/2" coupler for easy installation of optional moisture trap.



Media Blast Gun:

Lightweight aluminum pistol grip for long life. Interchangeable air jets and nozzles for various air supplies and media flow.

1/8" air jet supplied as standard. 5/32" – 3/16" air jets with sized nozzles supplied upon request.

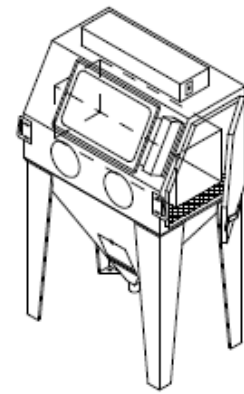

Fig. A

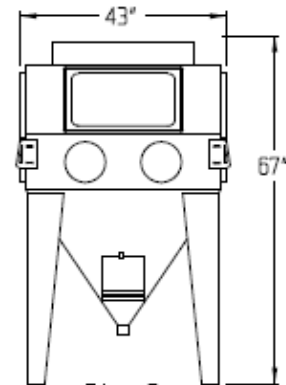

Fig. B

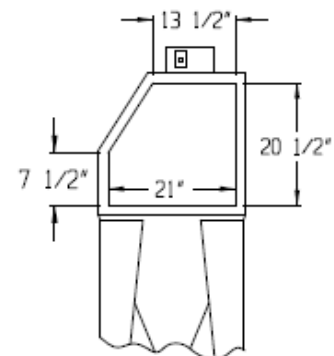

Fig. C

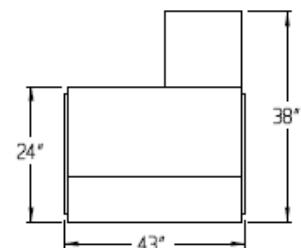

Fig. D



Mylar Roll & Mylar Dispenser