

LARRY HESS AND ASSOCIATES, INC
185 PIPER LANE / SALISBURY, NC 28147
PHONE: 1-800-535-2612 / FAX: 1-704-638-9311
WWW.BLAST-IT-ALL.COM

BLAST-IT-ALL® PRESSURE BLAST CABINET

NOTE: It is the responsibility of the user to read and understand this manual and to provide a safe work environment for any operator. No representation is intended as to the suitability of this equipment for any specific application. Media selection and production rates are the sole responsibility of the end user. The user takes full responsibility to insure compliance with regulations and safe operation on this equipment.



WARNING

DO NOT USE SAND. SAND WILL CAUSE SILICA DUST, WHICH IS THE CAUSE OF SILICOSIS DISEASE, A CONDITION OF MASSIVE FIBROSIS OF THE LUNGS. THIS STATEMENT INDICATES POTENTIAL PERSONNEL HAZARD.

**FAILURE TO COMPLY WITH THESE INSTRUCTIONS
MAY RESULT IN PERSONAL INJURY.**

WEBSITE CONCERNING SILICOSIS:

http://www.osha.gov/Silica/IT69D_1.html

MANUAL NUMBER: 573 DATE OF ISSUE: MARCH 2006

TABLE OF CONTENTS

SECTIONS

		PAGES
SECTION I	GENERAL INFORMATION	1
SECTION II	UTILITY REQUIREMENTS	2
SECTION III	INSTALLATION	3-6
SECTION IV	MAINTENANCE	7
SECTION V	PRESSURE POT	8
SECTION VI	RECLAIMER	9
SECTION VII	DUST COLLECTOR	10-11
SECTION VIII	SAFETY BLAST CONTROLS	11
SECTION IX	TROUBLE SHOOTING	12-13

DRAWINGS

NUMBER	DESCRIPTION	PAGES
M117P	MACHINE FRONT	14
M129	LIGHT BOX	15
M7024	AIR CONTROLS	16
A4096	BLOW-DOWN RESTRICTOR	17
A698-M	BLAST HOSE TOP SUPPORT ASSEMBLY	18
	RECLAIM / PRESSURE (700 CFM)	19
	RECLAIM / PRESSURE (900 CFM)	20
	TRASH SCREEN	21
B4060-3	PRESSURE POT	22
	REPLACEMENT PARTS	23
	PRESSURE AIR CONTROLS	24
B2129	D10 (700 CFM) DUST COLLECTOR	25
B2131	D20 (900 CFM) DUST COLLECTOR	26
A5107	ELECTRICAL 120V	27
B5102-M	ELECTRICAL 208/230/460V	28

TABLES

TABLE I	NOZZLE / CFM / LB/ HR	3
TABLE II	RECLAIM/DUST BAGS	5
TABLE III	PRESSURE SYSTEM / MEDIA QTY.	7

SECTION I

DESCRIPTION AND GENERAL INFORMATION

1-1 Purpose and Scope

This publication contains operations and maintenance instructions with a trouble shooting guide and illustrated parts breakdown for the Larry Hess & Associates, Inc. Dry Blast Cabinet.

- 1-2 The blast cleaning machine is of the enclosed type. Parts for processing are loaded into the cabinet through doors on the right or left side of the cabinet. The operators hands are inserted into a pair of gloves to protect the operator and to retain the media in the enclosure. Observation of parts in process is through a tempered glass window in the cabinet front. The unit also contains a sealed, two tube, fluorescent light which illuminates the work area. Machines are equipped with a safety interlocks which control the blasting process and provides a measure of safety for the blast operator.

An externally supplied compressed air pressure propels the media for abrasive blasting cleaning. The air pressure is routed through a moisture separator, pressure regulator, and blast control to the nozzle.

The blast cleaning machine is equipped with a media reclaiming cyclone separator. Media, dust, and debris are returned from the cabinet sump for separation. Reusable material drops through a filter screen where large particles are trapped, and into the storage hopper for reuse. The cyclone separator is equipped with an adjustable slide tube assembly, which controls the amount of dust being removed from the media.

Air and dust exhausted from the cyclone separator may be contained by several means. Standard means is the use of a Dust Bag attached to the outlet of the blower.

OPTIONAL Dust collector systems that are offered and easily installed with the machine.

1-3 General Information

This machine is designed primarily for blast cleaning with glass beads, (size 3-13) or aluminum oxide (size 46-220). Other types and sizes of blast media require special consideration. The nozzle pressure and media is determined by the application.

SECTION II

UTILITY REQUIREMENTS

2-1 Air Requirements

Compressed air with sufficient CFM and pressure must be used. Normal blast pressure should not exceed 80 PSI. Air volume (CFM) must be sufficient to maintain correct blast pressure for the gun orifice used (see Table 1). Compressed air to the dry blast cabinet must be clean and dry. Water and/or oil in the compressed air will contaminate the media and cause clogging in the machine, nozzle, reclaimer and dust collecting system. Piping to the machine should be of the size of the machine inlet or larger to prevent pressure and volume loss.

TABLE 1

<u>Orifice</u>	<u>CFM</u>	<u>PSI</u>	<u>LBS/HR</u>
No. 1/8	21.0	80	115
No. 3/16	41.0	80	260
No. 1/4	72.0	80	460
No. 5/16	113.0	80	725

2-2 Electrical Requirements

The standard blast machine is equipped with a cord and plug for 120 volt , single phase, 60 HZ operation. All other voltages require termination wiring on the machine.

- A.** 1 HP, 120 Volt, 1 Phase, 60 HZ, 20 AMP circuit
- B.** 1 HP, 240 Volt, 1 Phase, 60 HZ, 10 AMP circuit
- C.** 2 HP, 240 Volt, 1 Phase, 60 HZ, 20 AMP circuit
- D.** 2 HP, 230 Volt, 3 Phase, 60 HZ, 20 AMP circuit
- E.** 2 HP, 460 Volt, 3 Phase, 60 HZ, 10 AMP circuit

Machines that are wired **for other than** 120 Volt, 1 Phase, use a step down transformer to power the lights and control voltage. Make sure machine and components are properly grounded as per local NEC requirements.

SECTION III

INSTALLATION - PRESSURE MACHINE

3-1 Location

In selecting a location for your blast cabinet the following should be taken into consideration:

- A. Access to electrical supply
- B. Access to compressed air supply
- C. Sufficient room around machine for parts handling
- D. Access to dust bag or dust collector for dust removal
- E. Access to reclaimer to clean trash screen and add media.
- F. Noise level of blasting operation to other operations
- G. High atmospheric humidity conditions where moisture is pulled into the cabinet

3-2 Installation

- A. Remove the plastic covering and any strapping holding the machine and components.
- B. Remove lag bolts holding the machine to the pallet, and remove from pallet. Place the machine in the desired location.
- C. Remove reclaim/pressure system from pallet and place unit behind cabinet.
- D. Select the proper size flex hose and two (2) clamps to connect reclaimer to the machine. Slide one end of the flex hose on the sump outlet of the machine and clamp in place. Slide the other end of the flex hose onto the reclaimer inlet and clamp in place.
- E. Connect blast hose to the media valve located on the bottom of the pressure pot. This is done by aligning the prongs of the coupling on the blast hose, to the other half of the coupling on the media valve. Turn the coupling until it locks in place. Insert a small wire or safety clip through the hole on each half of the coupling to prevent accidental uncoupling.
- F. Connect the plastic line (**marked red**) from the blast cabinet controls to the fitting on purge cylinder.
- G. Connect the 3/4 inch air line from controls to the fitting located on the pressure pot.
- H. **Dust Bag Installation:**

Remove the dust bag from its package and unfold. Slide dust bag opening over the outlet of the blower housing, making sure zippered end is in the down position. Using the proper clamp, secure dust bag to the blower housing.

TABLE 2

R-18 Reclaimer-700 CFM 1 Dust Bag
R-24 Reclaimer-900 CFM 2 Dust Bags

I. Dust Collector Installation D10 and D20:

Move the dust collector to a position close to the reclaimer. Slip one end of the flex hose (6 in. for D10 (700 CFM), 8 in. for D20 (900 CFM)) on the outlet adapter located on the top of the reclaimer and clamp in place. Slip the other end of the flex hose on the inlet damper of the dust collector and clamp in place. Connect the 1/4 inch plastic air supply line for the shaker valve to the fitting supplied on the compressed air line. **Be sure the slide gate on the bottom of the Dust Collector sump is in place and closed before starting the machine.**

J. If machine is wired for other than 120 volt single phase, wires from the machine should be terminated. **A qualified electrician should connect wiring to the motor. Check the side of the motor for correct wiring of desired voltage and wiring schematic.**

K. Connect compressed air line to the moisture trap located on the rear of the machine. (See Table 1 for compressed air requirements).

L. Connect proper electricity to the machine using motor data plate and Section 2-2 for guidance.

M. Connect a grounding conductor to an earth ground.
Example: Cold water pipe, ground rod, etc.

N. For machines with a dust collector, loosen the wing nut on the inlet damper handle. Move the handle to 3/4 open position and tighten wing nut to prevent damper from moving.

O. Slowly turn on compressed air supply.

P. Move switch to the OFF position and apply electrical power to the machine.

Q. Move the switch to its ON position. The two tube, fluorescent light will illuminate the interior of the cabinet and the blower motor will start.

R. Single Phase Machines: Fan rotation has been checked at factory.

S. Three Phase Machines:

Three phase motors must have the rotation of the blower checked before operating. **The fan must turn clockwise in the blower housing viewed from the top, of motor side of the blower housing.** If rotation is wrong, have a qualified electrician reverse rotation. If rotation is correct, press the switch marked Start and machine motor will start.

- T. Close all doors on the machine and reclaimer. If the machine includes a dust collector, make sure the slide gate has been installed. Insert one hand into a glove and hold the blast nozzle firmly. Activate the blast by pressing down on the foot valve. Observe the reading on the gauge. Adjust the regulator until the gauge reads 80 PSI. Release the foot valve and blast will stop. Activate and release foot pedal several times to become familiar with the feel of the blast.
- U. Stop the Reclaim Fan before adding media.
- V. Obtain the desired media selected for your operation. Open the reclaimer door and pour the correct amount of media into the hopper of the reclaimer (See Table 3). Close the reclaimer door and secure latch, making sure the reclaimer door is sealed.

Table 3

1 Cu. Ft. Pot	50 lbs
3 Cu. Ft. Pot	200 lbs

- W. Turn adjusting knob on media valve clockwise until it stops, this is the closed position. Turn adjusting knob counter-clockwise three (3) complete revolutions for initial setting. Later adjustments may be necessary.
- X. Insure that the 1/4 turn “Choke” valve (ITEM 4 DRAWING B4060-3) is full open (handle parallel to valve body.) The Choke valve is located on pressure pot, in the airline supplying air to the media valve. Later adjustment may be necessary.
- Y. Open the machine door and place a test piece onto the grate within reach of the gloves. Close the machine door and latch securely. Move switch to its ON position. Insert both hands into the gloves. Hold the piece to be blasted **firmly** in one hand, and the blast nozzle in the other. Activate the foot valve to begin blasting. **(Do not point nozzle at viewing window).**
- Z. The blasting technique is similar to spray painting, smooth continuous strokes are most effective. The distance of the nozzle from the part effects the size and results of the blast pattern. Normal use places the nozzle approximately 8 inches from the item, at approximately a 30 to 45 degrees. Several media sizes and pressures may be required to process many varied types of materials.
- AA. A proper media/air ratio must be obtained for efficient blasting. This is accomplished by adjusting the media valve and choke valve for a proper balance. Smaller blast nozzles may require reducing the airflow going to the media valve. This is accomplished by partially closing the 1/4 turn choke valve. The amount the choke valve is closed depends upon the blast pressure desired, media flow, and the size of the blast nozzle. Adjustments should be made in small increments until proper balance can be obtained. Adjustments to the media valve should be made in 1/4 turn increments until proper media/air ratio is obtained. Media flow that is too heavy will cause pulsating of the blast stream. Media flow that is too light will not produce satisfactory blast results. The choke valve should be operated as open as possible and still produce desired blast results.

CC. Dust Removal - Dust Bags:

Obtain a container and place under the dust bag. Use the zipper in the bottom of the dust bag to open the bag and allow the accumulated dust to flow into the container. When the dust has been transferred into the container, close the dust bag by moving the zipper to its closed position.

CAUTION: Never open Dust Bag with Motor Running!

DD. Dust Removal - Dust Collector:

With motor off, press the button of the air operated vibrator valve mounted on the side of the dust collector. When vibrator is activated, you will be able to hear the vibrator shaking the bags inside the dust collector. The vibrator should be activated for one (1) minute before releasing. Obtain a container and place under the slide gate on the sump of the dust collector. **Slowly** move slide gate to its OPEN position and the accumulated dust will flow into the container. When dust has stopped flowing, Close the slide gate.

CAUTION: NEVER ACTIVATE SHAKER OR SLIDE GATE WITH MOTOR RUNNING

Note:Dust removed from the dust bag or dust collector must be disposed of in an approved manner. This dust is WASTE and should **NEVER BE PUT BACK INTO THE MACHINE.**

SECTION IV

MAINTENANCE

4-1 Before Each Use:

- A. Check moisture trap and drain if needed
- B. Visually inspect machine for any unsafe condition
- C. Turn on compressed air supply
- D. Turn on electricity

4-2 After Each Use:

- A. Turn off blower fan
- B. Activate shaker valve on dust collector
- C. Turn off electricity
- D. Turn off compressed air supply
- E. Drain moisture trap

4-3 Daily Inspection:

- A. Clean trash screen and empty.
- B. Empty dust bag or dust collector

4-4 Weekly Inspection:

- A. Dust bags in dust collector
- B. Blast nozzle for wear
- C. Machine door gaskets
- D. Reclaimer door gasket
- E. Air hoses for leaks and loose clamps
- F. Blast hose for holes or soft spots

4-5 As Needed:

- A. Add media
- B. Replace bags
- C. Replace worn gloves
- D. Replace window
- F. Replace any worn or defective blast parts
- G. Replace gaskets
- H. Replace hoses

SECTION V

PRESSURE POT

5-1 Operation -

All pressure pots, regardless of size, work basically in the same manner. Air controls, purge valves, media valves, and means of activation may vary widely for specific applications, and between manufactures. When blast is activated, the pressure pot purge valve is closed and compressed air is allowed to enter the pot. The on-rush of compressed air into the pot forces the plunger to close and seal, pressurizing the pot. As this occurs, compressed air forces media out the media valve. As the media flows out the media valve it is picked up in the compressed air from the choke valve and continues flowing to the blast nozzle. Blast continues until pot is deactivated. At this time, compressed air is stopped and the purge line is opened. When the purge line is opened the pot is depressurized allowing the plunger to open. When the plunger opens, media that has been stored in the hopper above the pot is allowed to flow into the pressure pot, recharging it for the next sequence of blast.

5-2 Choke Valve Adjustment

Correct operation of a pressure blast system requires a small differential of pressure across the media valve. By closing the choke valve slightly and decreasing the flow of air to the media valve and nozzle, the pressure differential across the media valve can be increased without effecting flow from the nozzle. This increase in differential pressure causes media to flow through the media valve more evenly. Adjustment of the choke valve should be in small increments because the pressure differential across the media valve should be very small.

5-3 Media Adjustment

To obtain satisfactory blast results, the media/air ratio to the blast nozzle must be balanced correctly. Sufficient media must be mixed with the compressed air for efficient blasting, but too much media reduces the blast effect. The most noticeable effect of too much media is a surging or pulsating of the air/media mixture at the blast nozzle. If this condition exists, the flow of media through the media valve should be reduced. **TURN THE MEDIA VALVE KNOB CLOCKWISE.** This adjustment should be made in small increments until a satisfactory air/media ration is obtained.

5-4 Blast Pressure Adjustment

Blast pressure must be determined for each blasting process. This may require several test pieces to be blasted at different pressure to obtain proper results. Correct blast pressure is maintained by a regulator on the incoming compressed air line. A pilot operated regulator uses a compressed air supply to vary its output. This air is supplied by a smaller, remotely located, manual regulator. The output of the Pilot regulator, is proportional to the pressure applied by the control regulator, and may be read by the gauge at the control regulator. Sufficient blast pressure must be maintained to allow the plunger inside the pressure pot to seal. If the plunger does not seal, the pressure tank cannot pressurize.

SECTION VI

RECLAIMER AIR WASH

6-1 Operation

Reclaimer/Dust Bag: A4083A (900 CFM) - A4084A (700 CFM)

Media, dust and debris are removed from the blast cabinet and enters the reclaimer through the inlet (25). The air flow created by the blower assembly (27,28,29,30) causes the mixture removed from the cabinet to begin spinning in the reclaimer body (2). This spinning action separates the dust and small particles from the good media and debris. The dust is pulled from the reclaimer body (2) through the inner tube assembly (22,36) by the air velocity and discharges into the dust bag. Good media and debris falls to the trash screen (35), where the debris is trapped and re-usable media passes through, to be used again. The amount of dust and small particles removed may be varied (See 6-3 adjustment).

6-2 Operation

Pull-Through- A4083 (900 CFM) - A4084 (700 CFM)

The internal operation of a pull-through reclaimer is the same as described in 6-1; the only difference is that the motor assembly is located on the dust collector. An adapter is bolted onto the reclaimer in place of the blower assembly and a flex hose connects the reclaimer to the dust collector. The dust collector is equipped with an inlet damper which must also be adjusted (See 7-4, damper adjustment).

6-3 Air Wash Adjustment (SEE DRAWINGS A4083-N & A4084-N)

Placement of the slide tube (5) for each type of blasting application cannot be a pre-determined setting. Many factors contribute to the air wash adjustment such as media type, media size, desired finish of part, etc. Adjustment of the slide tube (5) must be made in small increments (approximately 1/4 inch.) in the direction needed to prevent over adjustment.

Adjust slide tube (5) up, when good media is found in the material removed from the dust bag or dust collector. **Adjust the slide tube (5) down**, when excessive dust is found mixed with the media. To adjust the slide tube (5), move the switch to its OFF position and allow the motor to stop. Disengage reclaimer door latch (2) and open the access door (3). Insert arm into reclaimer housing routing hand upward through the inner cone until the round slide tube is felt.

Loosen the locking "T" handle located inside the slide tube (5), by turning counter-clockwise. Move the slide tube (5) in the determined direction and lock in place by turning "T" handle clockwise. Carefully remove arm and close access door (3) and engage access door latch (2) to insure air tight seal. The machine should be operated under blast condition until the media has been circulated through the reclaim several times. Inspect media and dust again to determine if further adjustment is needed.

SECTION VII

DUST COLLECTOR

7-1 Operation - Ref. Dwg. B2129, B2131

The D10 (700 CFM) and D20 (900 CFM) Dust Collectors operate in the same manner; the area of dust collecting is the only operation difference. The dust bags are equipped with one end closed while the other end remains open. The blower assembly mounted on side of the dust collector creates a air flow through the dust bags. This airflow draws air, media, dust and debris from the blast cabinet into the reclaiming, where the dust is separated. The dust-laden air from the reclaiming is drawn into the dust bags where the dust is trapped inside the bags. Clean air is then allowed to pass through the bags and exhausted from the blower assembly.

7-2 Cleaning

The bag hanger is equipped with an air-operated vibrator. This vibrator is activated by an air push button located on the side of the dust collector. Cleaning of the dust bags and emptying the dust from the sump is very critical for correct operation of the blast machine. Failure to clean the dust bags reduces air movement in the blast machine and reclaiming. Results of reduced air movement includes excessive dust in cabinet, improper reclaiming, etc. (See Trouble Shooting Guide).

Dust bags should be shaken after each use or more often if needed. To shake the dust bags, first move the switch to its OFF position and allow motor to stop rotating. Press the button on the shaker valve and hold for one minute. With motor off, place a container under the slide gate in the sump of the dust collector. Move slide gate to its open position and allow dust to flow into the container. Move slide gate to its closed position. **DISPOSE OF DUST IN AN APPROVED MANNER.** Do not cycle dust back into the system. Do not shake bags or open sump slide gate when motor is operating. Remove wing nuts and remove access door weekly and inspect dust bags. After extended use, the dust bags will become saturated with dust and will not pass sufficient air. At this time remove the dust bags and replace with new

bags.

7-3 Bag Replacement

Move the switch to its OFF position. Shake dust bags and empty sump as described in 7-2. Turn air supply to the unit off. Remove wing nuts and remove access door. Remove the closed end of the dust bag from the bag hanger at the top of the collector. Starting at the front, remove the bags from the bag holder. The open end of the bag has two coil springs sewn into the felt material. One spring is on each side of the bag holder. Pushing the springs inward will allow the bag to slip from its mounting hole.

Caution: Personnel protection should be taken against any dust that might escape during bag replacement. Some blasted items may produce dust that is harmful. Know what your dust contains.

To install new bags, begin by hanging the bags on the bag hanger using the loop sewn into the closed end of the bag. With the bags hanging in place, begin at the rear of the machine installing the open end of the dust bag into the bottom bag holder. Place one spring on each side of the bag holder metal. Working forward, install all bags carefully into their respective hole being careful not to cross any bags. Do not use any sharp object to install bags in bag holder. When all bags have been installed correctly, inspect and replace any worn gasket around the access door. Re-install door and tighten all wing nuts. When the blast machine is restarted, observe the exhaust from the blower for traces of dust. If dust is detected, remove access door and inspect bag installation and dust bags.

7-4 Damper Adjustment

Due to increased efficiency over the standard dust bag, the D10 and D20 dust collectors are equipped with an inlet damper. The inlet damper has an external adjustable handle which can be locked in place with a wing nut. The inlet damper should be open enough to maintain sufficient air flow for correct reclaiming and to clean dust from the cabinet. If inlet damper is open too far, it will tend to pull good media out of the reclaimer. Inspection of the dust removed from the dust collector will determine if the damper is open too far. A correct balance of the inlet damper of the dust collector and the air wash in the reclaimer will produce maximum use of selected media.

SECTION VIII

Safety Blast Control

8-1 Operation

A. Air Operated

A safety air valve is located above each cabinet door. This valve is activated when door(s) are closed.

WARNING: By-passing safety valve could cause a hazardous condition to personnel

Section IX

TROUBLE	SOLUTION
9-A No Blast - No Air or Media	
<u>Probable Cause</u>	
1. Air supply to machine turned off.	Turn on air supply.
2. Regulator adjusted too low	Set regulator to 80 PSI
3. Foot valve bad.	Replace as needed
4. Nozzle or media valve plugged.	Depressurize blast machine, remove nozzle and check for obstruction. If no obstruction is found check the media valve.
5. Air safety interlock	Check & replace if needed
6. Main regulator bad.	Check & replace if needed
7. Control regulator bad.	Check & replace if needed
9-B No Media from Blast Nozzle (Air Only)	
<u>Probable Cause</u>	
1. Out of media	
2. Media valve plugged.	Remove and inspect
3. Plunger stuck closed (no media transferring from reclaim to pressure pot.)	Inspect plunger.
4. Trash screen clogged.	Empty screen drawer Daily maintenance.
9-C Blast Nozzle Surging	
<u>Probable Cause</u>	
1. Media valve set too rich.	Adjust, lean media flow (TURN CLOCKWISE)
2. Choke valve closed too much	Open choke valve, SMALL ADJUSTMENTS
3. Contaminated media (WET OR OILY MEDIA)	Remove and replace media
9-D Cabinet Cloudy	
<u>Probable Cause</u>	
1. Low air movement	Check and empty dust filter(s) Make sure cabinet air inlets are not blocked
2. Media too old / too fine	Replace with new media

TROUBLE	SOLUTION
9-E Low or No Air Movement	
<u>Probable Cause</u>	
1. Fan motor not running	Check motor/fan rotation.
2. Fan motor running in reverse	Reverse rotation. (See 3-2-S)
3. Incorrect fan speed.	Check for correct motor voltage.
4. Fan blade worn	Replace fan blade
5. Dust bag full.	Empty dust bag
6. Dust collector full.	Shake bags and empty dust collector sump
7. Air intake holes in blocked	Remove any obstructions covering holes
8. Inlet damper closed.	Adjust inlet damper. (See 7-4)
9. Flex hose – machine to reclaim.	Flex hose off – replace
9-F Reclaimer Not Separating (Dust in Media)	
<u>Probable Cause</u>	
1. Contaminated media	Replace media
2. Adjustable air wash in reclaimer set too high	Re-set air wash
3. Low air movement.	Check as per 9E
9-G CONTAMINATION OF MEDIA	
<u>Probable Cause</u>	
1. Condensation in compressed air.	Drain moisture trap more often
2. Oil in compressed air from air compressor	Install coalescing filter in compressor air supply.
3. Machine oil or cleaning solvents on	Parts being blasted should be cleaned in a solution That leaves no residue.
4. Atmospheric Humidity.	Machine should be placed in a location where large amounts of outside humid air is not drawn through the system.
9-H Pressure Pot Plunger not Sealing	
<u>Probable Cause</u>	
1. Insufficient air supply to pressure pot.	A. Blast pressure too low. B. Bad check valve. C. Insufficient compressed air supply. D. Bad pressure regulator
2. Worn Plunger	Remove and inspect, replace if needed.
3. Worn Plunger seal.	Remove “seal” Inspect and replace
4. Plunger not aligned.	Remove access port and aligned plunger.

LARRY HESS & ASSOCIATES
 STANDARD MACHINE REPLACEMENT PARTS
 DATE 4/23/96
 ENGINEER DEC
 DWG. NO. M117P

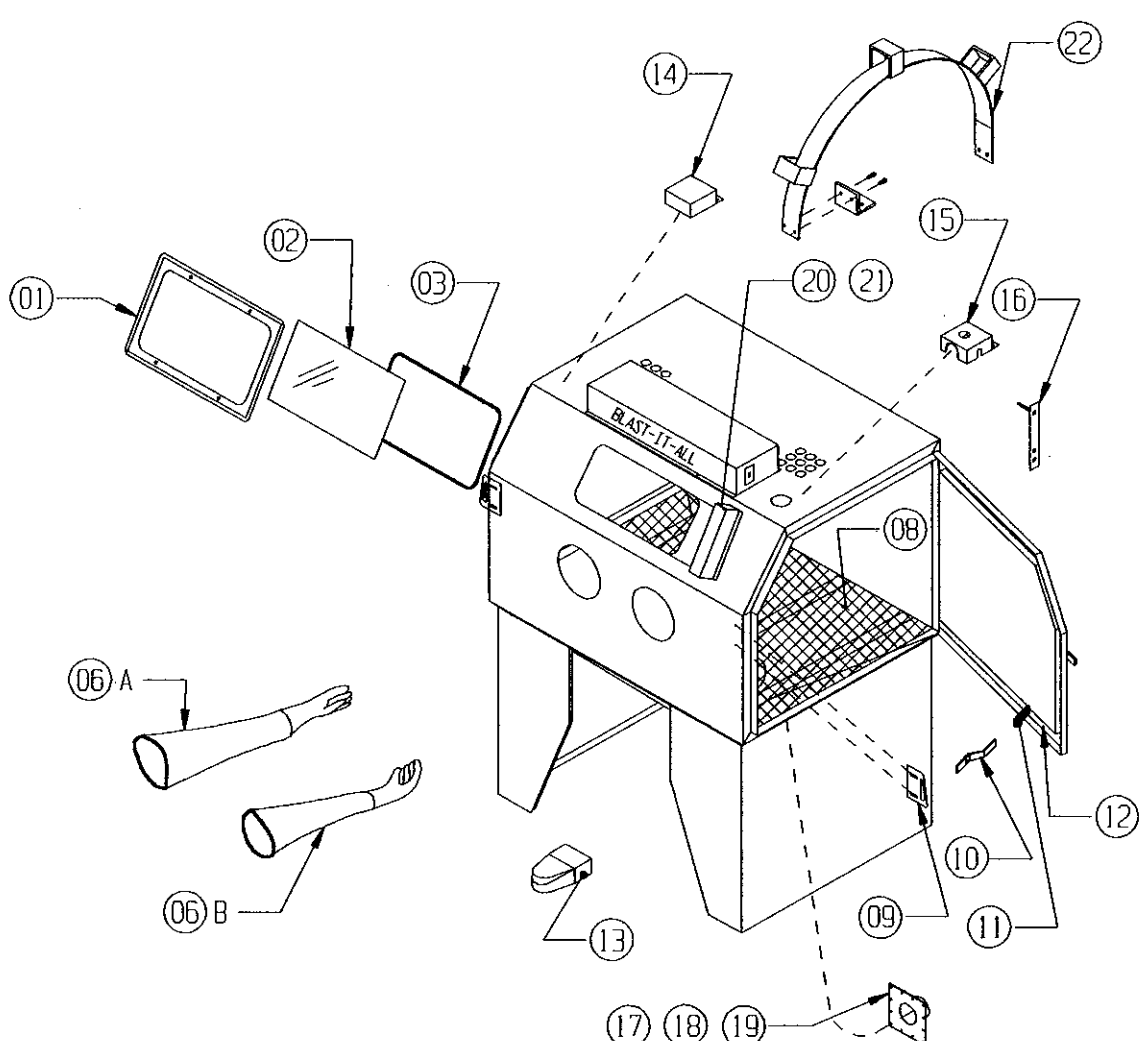

ITEM NO.	PART NO.	DESCRIPTION
1	23-053	WINDOW FRAME
2	23-050	WINDOW, VIEWING
3	24-059	WINDOW GASKET (SPECIFY LENGTH)
4	-----	-----
5	-----	-----
6	22-077	GLOVE, CLAMP ON (LEFT ONLY)
6A	-----	-----
6B	22-078	GLOVE, CLAMP ON (RIGHT ONLY)
7	-----	-----
8	-----	GRATE (REFER TO CHART #1)
9	15-730	DOOR STRIKER (EITHER SIDE)
10	15-719	DOOR CAM (EITHER SIDE)
11	15-720	DOOR CAM RUBBER GRIP
12	-----	DOOR GASKET (REFER TO CHART #2)
13	003190	FOOT VALVE
14	A117	SAFETY VALVE PANEL
15	A7170	CONTROL REGULATOR PANEL
16	A237	SAFETY DOOR CONTROL ARM
17	11-705	Ø 4" SUMP OUTLET
18	11-905	Ø 5" SUMP OUTLET
19	11-905-6	Ø 6" SUMP OUTLET
20	011191	MYLAR GLASS PROTECTOR
21	011190	MYLAR HOLDER
22	REF. A698	HOSE SUPPORT

CHART #1

MACHINE MODEL	GRATE PART NO.
3636	10-111
4426	10-112
4836	10-114
4848	10-115
6048	10-117
6060	10-118

CHART #2

MACHINE MODEL	DOOR GASKET NO.
3636	24-025-12'
4426	24-025-9'
4836	24-025-13'
4848	24-025-15'
6048	24-025-16'
6060	24-025-18'

* EACH DOOR

LARRY HESS & ASSOCIATES

DESCRIPTION

BIA LIGHT BOX

DATE

4/23/96

ENGINEER

DEC

DWG. NO.

M129

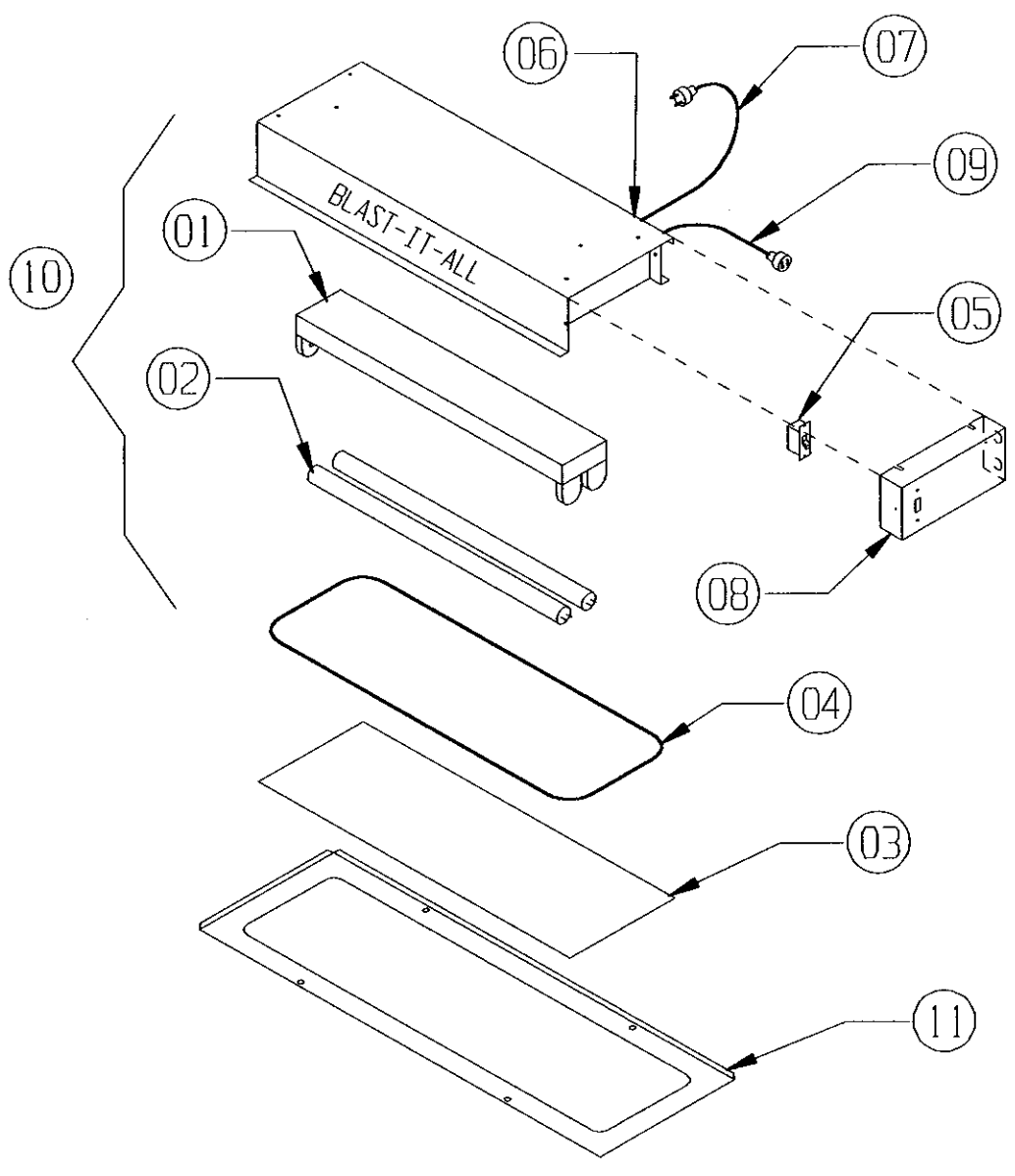

ITEM NO.	PART NO.	DESCRIPTION
1	13-533	FLUORESCENT FIXTURE, (NO TUBES)
2	13-534	24" FLUORESCENT TUBE
3	23-058	PROTECTOR, LIGHT
4	23-059	GASKET
5	13-655	SWITCH
6	13-605	ROUND CONNECTOR
7	13-550	POWER CORD, 3 WIRE
8	B198-2	SWITCH MOUNTING PLATE
9	010172F	CORD WITH FEMALE PLUG
10	010801	COMPLETE LIGHT BDX (EXCEPT 3 & 4 & 11)
11	A506	LIGHT BOX WINDOW FRAME

LARRY HESS & ASSOCIATES

DESCRIPTION

PRESSURE AIR CONTROL

DATE

5/01/96

ENGINEER

DEC

DWG. NO.

M7024

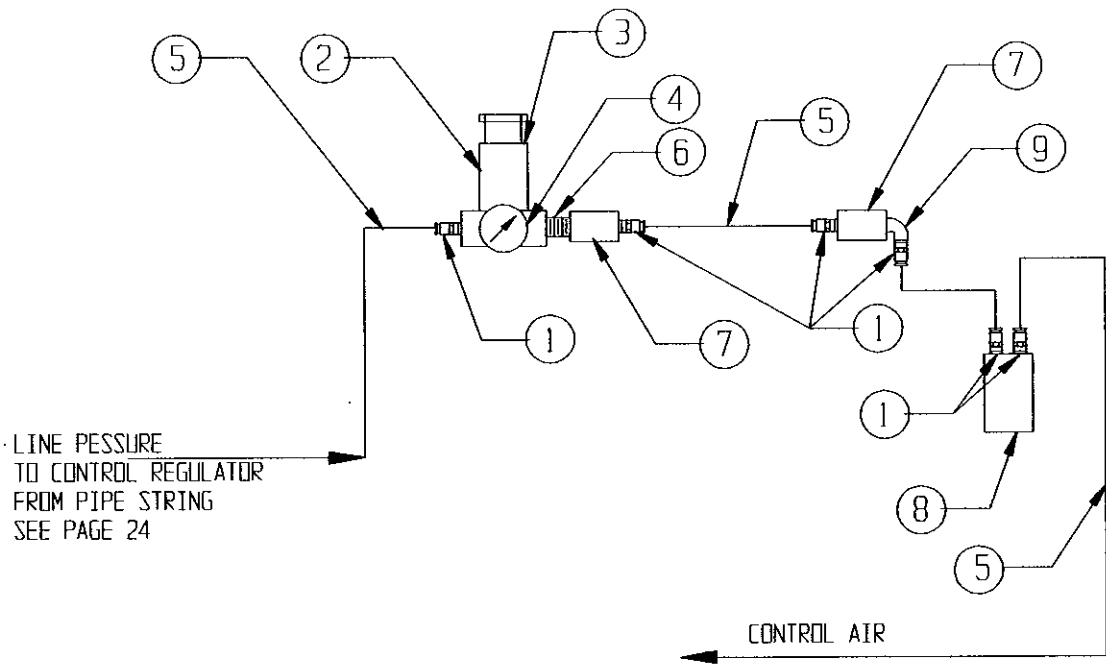

ITEM NO.	PART NO.	QTY.	DESCRIPTION
1	16-951	7	FITTING 1/4" TUBE x 1/8" NPT
2	001564	1	REGULATOR, 1/8"
3	001564-N	1	NUT FOR REGULATOR
4	16-820	1	GAUGE, 1/8" BACK
5	18-111	*	TUBING 1/4", D.D, VINYL
6	002405	1	CLOSE NIPPLE, 1/8"
7	010600	2	VALVE. AIR 1/8" 3-WAY (SAFETY DOOR)
8	003190	1	VALVE. AIR (FOOT CONTROL)
9	001129	1	1/8" STREET ELL

A4096M

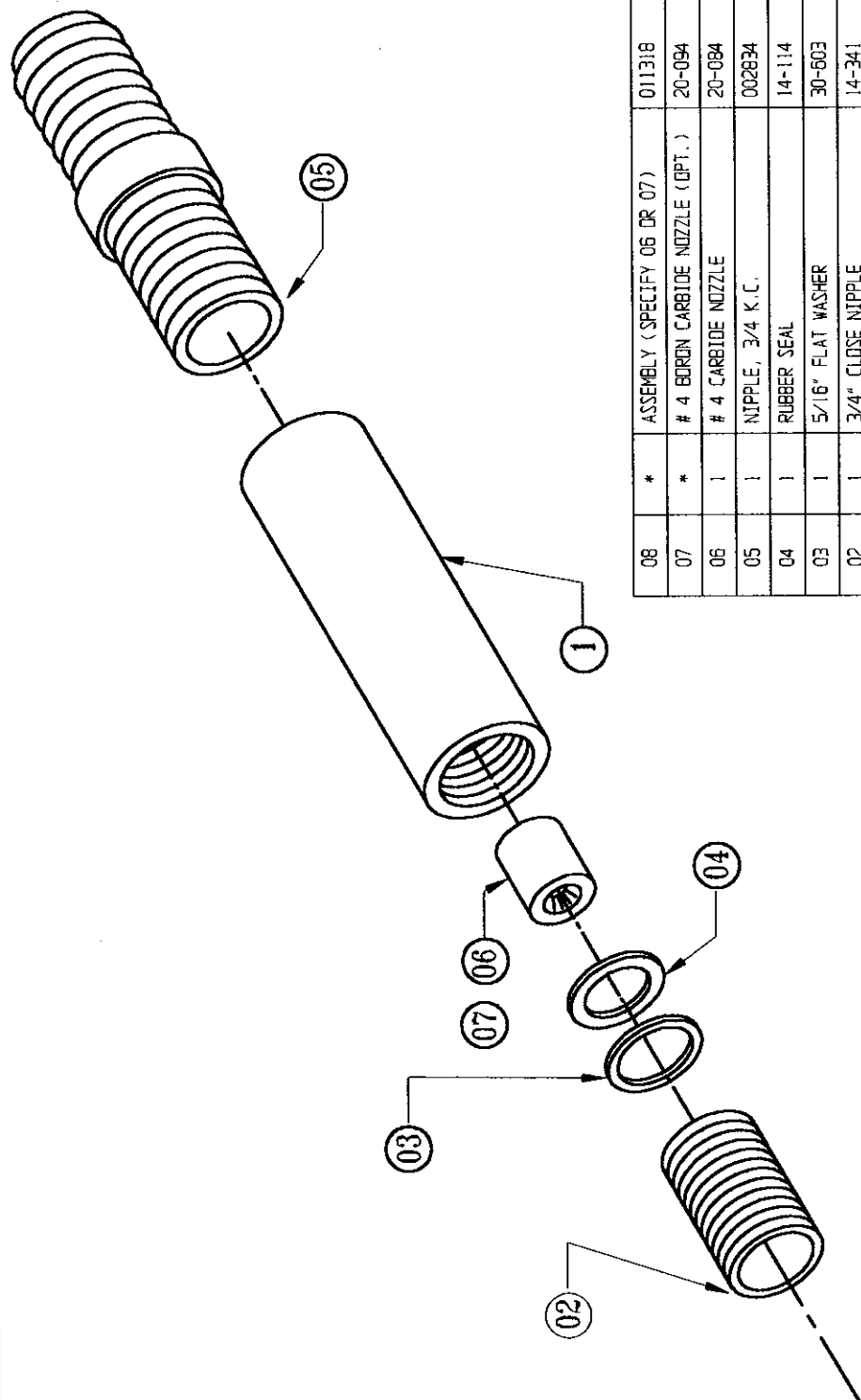

08	*	ASSEMBLY (SPECIFY 06 OR 07)	011318
07	*	# 4 BEYON CARBIDE NOZZLE (OPT.)	20-094
06	1	# 4 CARBIDE NOZZLE	20-084
05	1	NIPPLE, 3/4 K.C.	002834
04	1	RUBBER SEAL	14-114
03	1	5/16" FLAT WASHER	30-603
02	1	3/4" CLOSE NIPPLE	14-341
01	1	HOLDER	011319
ITEM NO.		QTY.	DESCRIPTION
			DWG. NO./ MATERIAL

LARRY HESS & ASSOCIATES, INC.
SALISBURY NORTH CAROLINA

DESCRIPTION: BLOW DOWN RESTRICTOR
MATERIAL:

DRAWN BY:	LJF	DATE:	06/14/00	SCALE:	1/4" = 1"	JOB NO.:	STD.	
CHK'D BY:		DATE:		FRACTIONAL:	DECIMAL:	NEET ASS'Y:		
							DRAWING NO.:	A4096M

CONFIDENTIAL

THE DISCLOSURES AND CONTENTS OF THIS DRAWING ARE CONFIDENTIAL AND ARE THE EXCLUSIVE PROPERTY OF BLAST-IT-ALL © A DIV. OF LARRY HESS & ASSOCIATES, INC. THIS DRAWING IS NOT TO BE COPIED OR REPRODUCED WHOLLY OR IN PART WITHOUT WRITTEN PERMISSION OF LARRY HESS & ASSOCIATES, INC.

REV.	DESCRIPTION	BY	DATE

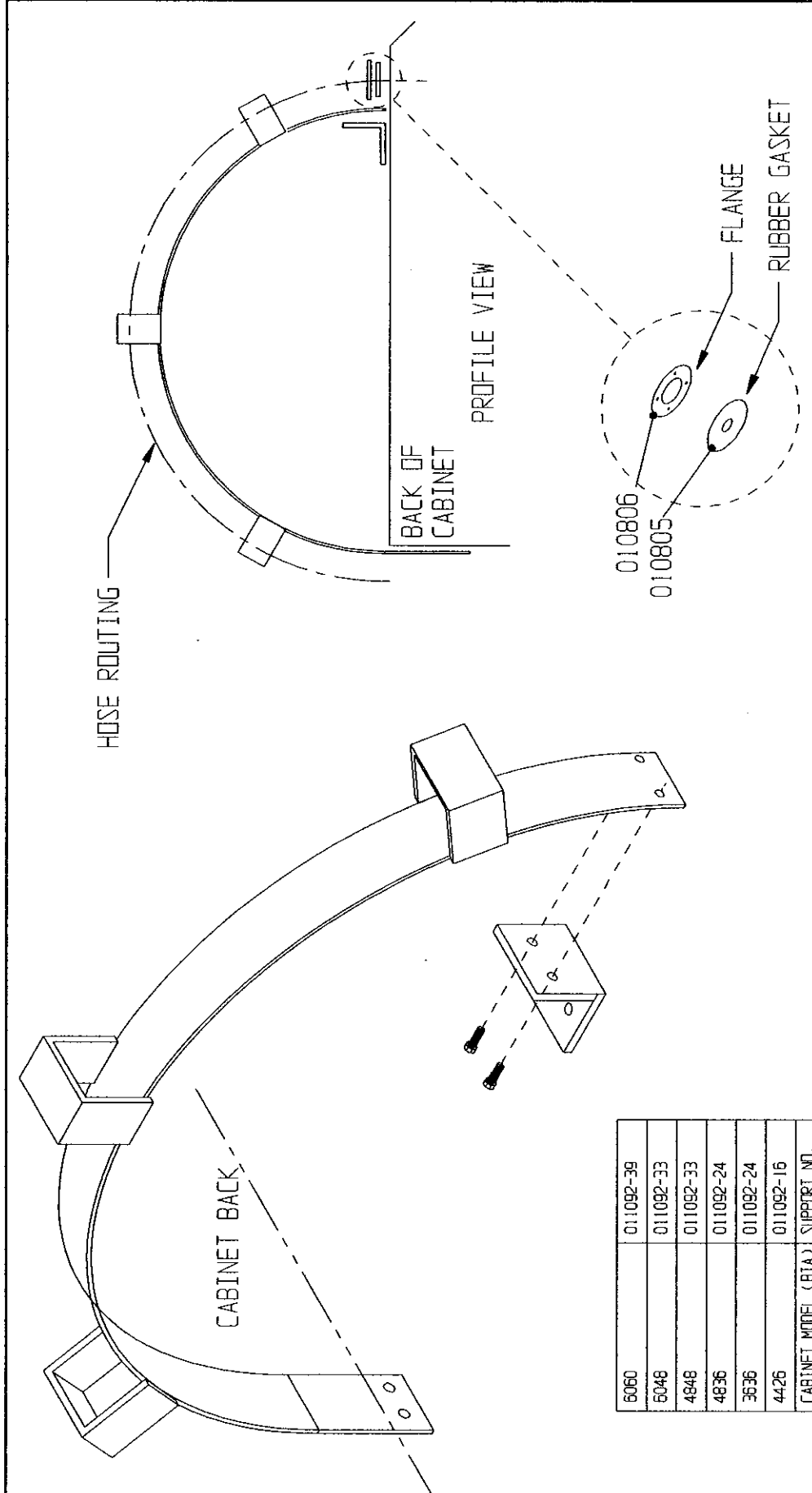

6060	011092-39
6048	011092-33
4848	011092-33
4836	011092-24
3636	011092-24
4426	011092-16
	CABINET MODEL (BIA) SUPPORT NO.

LARRY HESS & ASSOCIATES, INC.
SALISBURY NORTH CAROLINA

DESCRIPTION: BLAST HOSE TOP SUPPORT ASSEMBLY

DATE: 01/02/06
SCALE: N. T. S.
JOB NO.:
MATERIAL:

DATE: DEC
DATE: 01/02/06
SCALE: N. T. S.
JOB NO.:
MATERIAL:

DATE: DEC
DATE: 01/02/06
SCALE: N. T. S.
JOB NO.:
MATERIAL:

DRAWING NO.: A698-MBIA

CONFIDENTIAL

THE DISCLOSURES AND CONTENTS OF THIS DRAWING ARE CONFIDENTIAL AND ARE THE EXCLUSIVE PROPERTY OF BLAST-IT-ALL © A DIV. OF LARRY HESS & ASSOCIATES, INC. THIS DRAWING IS NOT TO BE COPIED OR REPRODUCED WHOLLY OR IN PART WITHOUT WRITTEN PERMISSION OF LARRY HESS & ASSOCIATES, INC.

REV.	DESCRIPTION	BY	DATE

P01R18 (700 CFM) PRESSURE SYSTEM (STANDARD MACHINE)

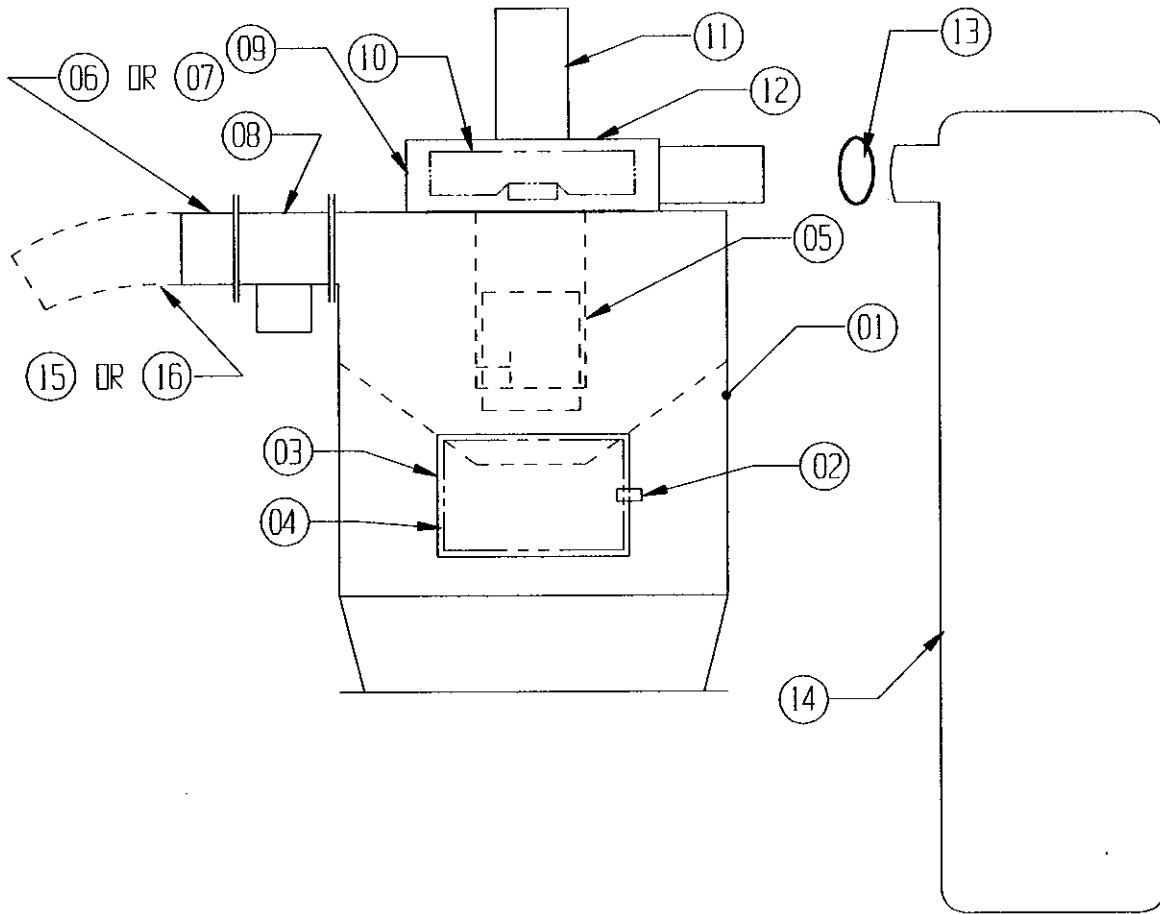

ITEM NO.	PART NO.	DESCRIPTION
1	11-701P	RECLAIM BODY
2	15-728	RECLAIM DOOR LATCH
3	11-702	RECLAIM DOOR W/GASKET
4	11-703	RECLAIM DOOR GASKET
5	11-731	INNER SLIDE TUBE
6	11-705	INLET ADAPTOR 4"
7	11-905	INLET ADAPTOR 5"
8	010077	PURGE ADAPTOR
9	11-716	BLOWER HOUSING
10	11-718	BLADE
11	13-700	MOTOR, 1 HP
12	11-720	MOTOR PLATE
13	21-036	CLAMP
14	11-715	DUST BAG
15	19-092	FLEX HOSE, 4"
16	19-094	FLEX HOSE, 5"

P01R24 (900 CFM) PRESSURE SYSTEM (STANDARD MACHINE)

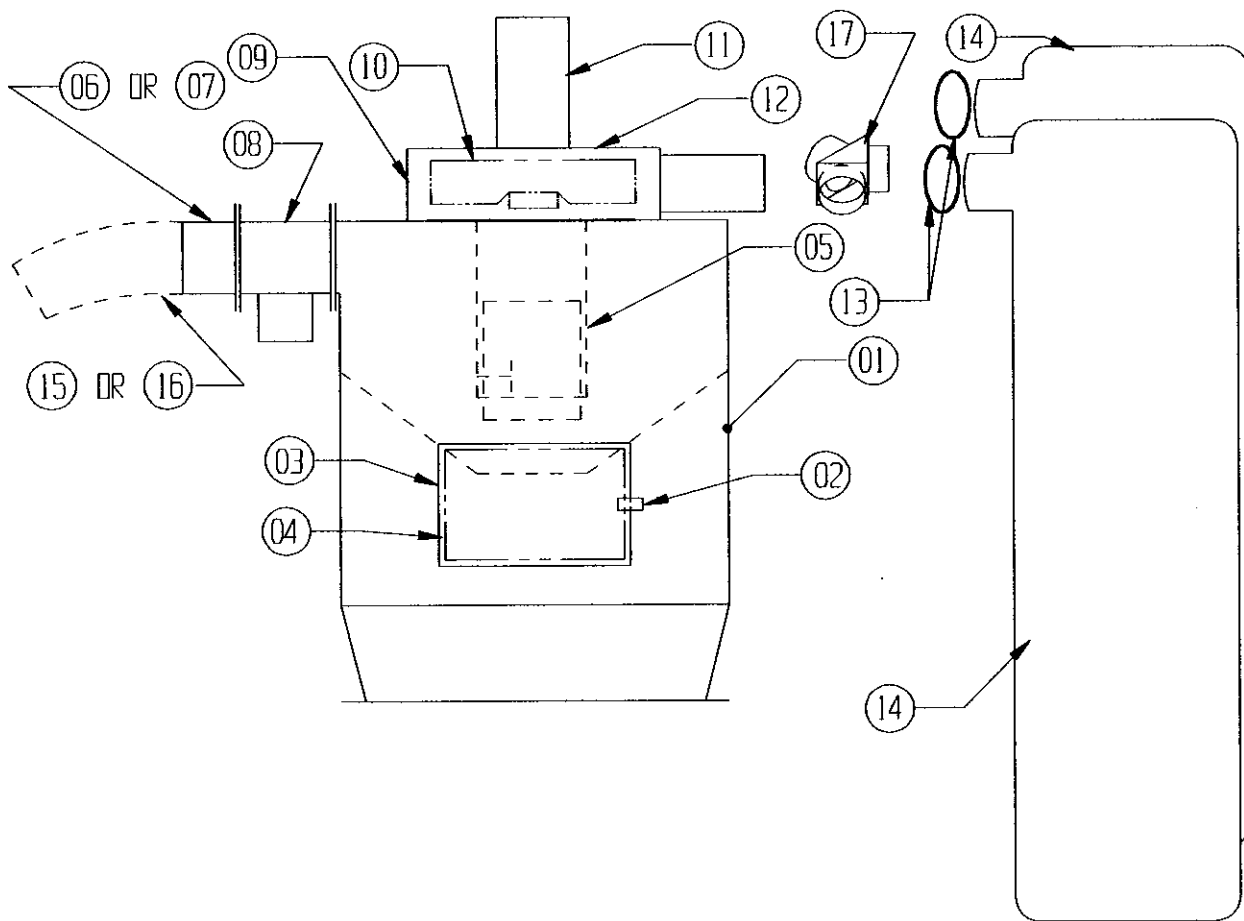

ITEM NO.	PART NO.	DESCRIPTION
1	11-901P	RECLAIM BODY
2	15-728	RECLAIM DOOR LATCH
3	11-902	RECLAIM DOOR W/GASKET
4	11-903	RECLAIM DOOR GASKET
5	11-931	INNER SLIDE TUBE
6	11-905	INLET ADAPTOR 5"
7	A12767	INLET ADAPTOR 6"
8	010077	PURGE ADAPTOR
9	11-916	BLOWER HOUSING
10	11-918	BLADE
11	13-900	MOTOR, 2 HP
12	11-720	MOTOR PLATE
13	21-036	CLAMPS (2)
14	11-915	DUST BAGS (2)
15	19-094	FLEX HOSE, 5"
16	19-096	FLEX HOSE, 6"
17	11-912	OUTLET "Y" (WYE)

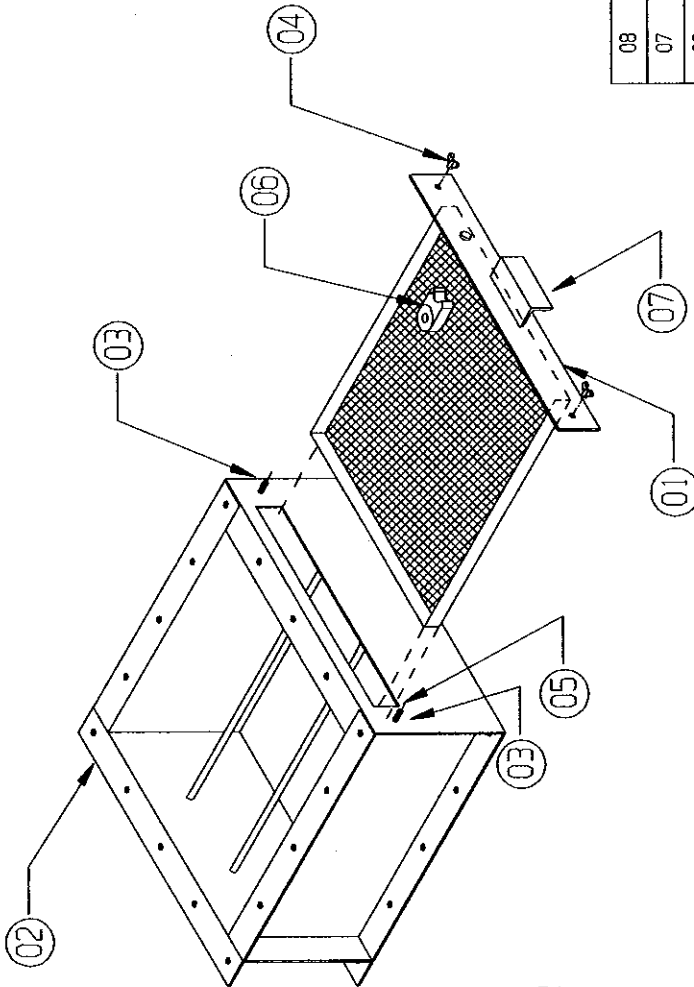

08	1	REPLACEMENT DRAWER (1/4" HOLES)	010581-1
07	1	REPLACEMENT DRAWER (3/16" HOLES)	010581
06	1	VIBRATOR (OPTIONAL)	16-919
05	3 FT.	1/8" x 3/4" GASKET	24-021
04	2	1/4" WING NUT	30-510
03	2	1/4" SELF TAPPER x 3/4" LONG	30-112
02	1	TRASH SCREEN BOX ASS'Y.	A268
01	1	DRAWER ASS'Y.	A270
ITEM NO.		QTY.	DESCRIPTION
			DWG. NO. / MATERIAL

LARRY HESS & ASSOCIATES, INC.
SALISBURY NORTH CAROLINA

DESCRIPTION: TRASH SCREEN ASM.
010580

MATERIAL:

DATE:	6/14/99	SCALE:	3/32" = 1"	AS. NO.	STD.
CHK'D BY:		FRACTIONAL:		NET ASY.:	
		DECIMAL:			
		ANGLE:			

DRAWING NO.:

A673-A

CONFIDENTIAL

THE DISCLOSURES AND CONTENTS OF THIS DRAWING ARE CONFIDENTIAL AND ARE THE EXCLUSIVE PROPERTY OF BLAST-IT-ALL A DIV. OF LARRY HESS & ASSOCIATES, INC.. THIS DRAWING IS NOT TO BE COPIED OR REPRODUCED WHOLLY OR IN PART WITHOUT WRITTEN PERMISSION OF LARRY HESS & ASSOCIATES, INC..

REV.	DESCRIPTION	BY	DATE

1.0 CU. FT. PRESSURE VESSEL

33	1	NIPPLE, 1" CLOSE	14-357
32	1	BLOW-DOWN RESTRICTOR	011318
31	1	NIPPLE, 1-1/4" CLOSE	14-350
30	1	BUSHING, 1" x 1-1/4"	14-363
29	1	NIPPLE, 3/4" x 3" LG.	14-520
28	1	FITTING, STRAIGHT CONNECTOR 1/4" x 1/4"	004623
27	1	PLUG, 3/4"	000835
26	7	NIPPLE, CLOSE 3/4"	14-341
25	2	BUSHING, 1" x 3/4"	14-371
24	1	NOZZLE, 1-1/4" THREADS	20-622
23	1	WASHER, NCW 1" ID x 1-1/2"	14-113
22	1	HOLDER, HOLDER 1-1/4" THREADS	14-109
21	1	NOZZLE, 1/4"	20-602
20	1	WASHER, NCW 1/2" ID x 1-1/8"	14-114
19	1	HOLDER, NOZZLE 3/4" THREADS	14-108
18A	1	VALVE, POP-UP, URETHANE (7/17/00)	16-706U
18	1	VALVE, POP-UP, STEEL	16-706
17	1	SEAL, POP-UP	16-707
16	1	TANK COUPLING 1-1/4 FPT 2 PRONG AL	14-117
15	2	WASHER, QC & TC	14-107
14	1	QUICK COUPLING 3/4" HOSE	14-102
13	1	QUICK COUPLING, 1/2" HOSE	14-101
12	5	3/4" K.C. NIPPLE	002834
11	1	PINCH VALVE ASMB.	16-1015
10	*	TUBING 1/4" OD VINYL	18-111
09	*	HOSE, BLAST 1/2" ID X 1-1/8 OD	18-100
08	*	HOSE, BLAST 3/4" ID X 1-1/2" OD	18-101
07	5	CLAMP	21-031
06	1	BELL REDUCER 1 1/2 X 3/4	006227
05	2	TEE 3/4" 150# MI	14-509
04	1	VALVE, BALL 3/4"	14-464
03	*	HOSE, AIR 3/4" I.D.	18-080
02	1	MICRO VALVE	16-878
01	1	PRESSURE POT 1 CU. FT.	16-935
ITM	QTY	DESCRIPTION	PART NO.

B4060-5PL

PO1 PRESSURE SYSTEM PIPE STREAM (STANDARD MACHINE)
LOCATED ON BACK OF BLAST CABINET

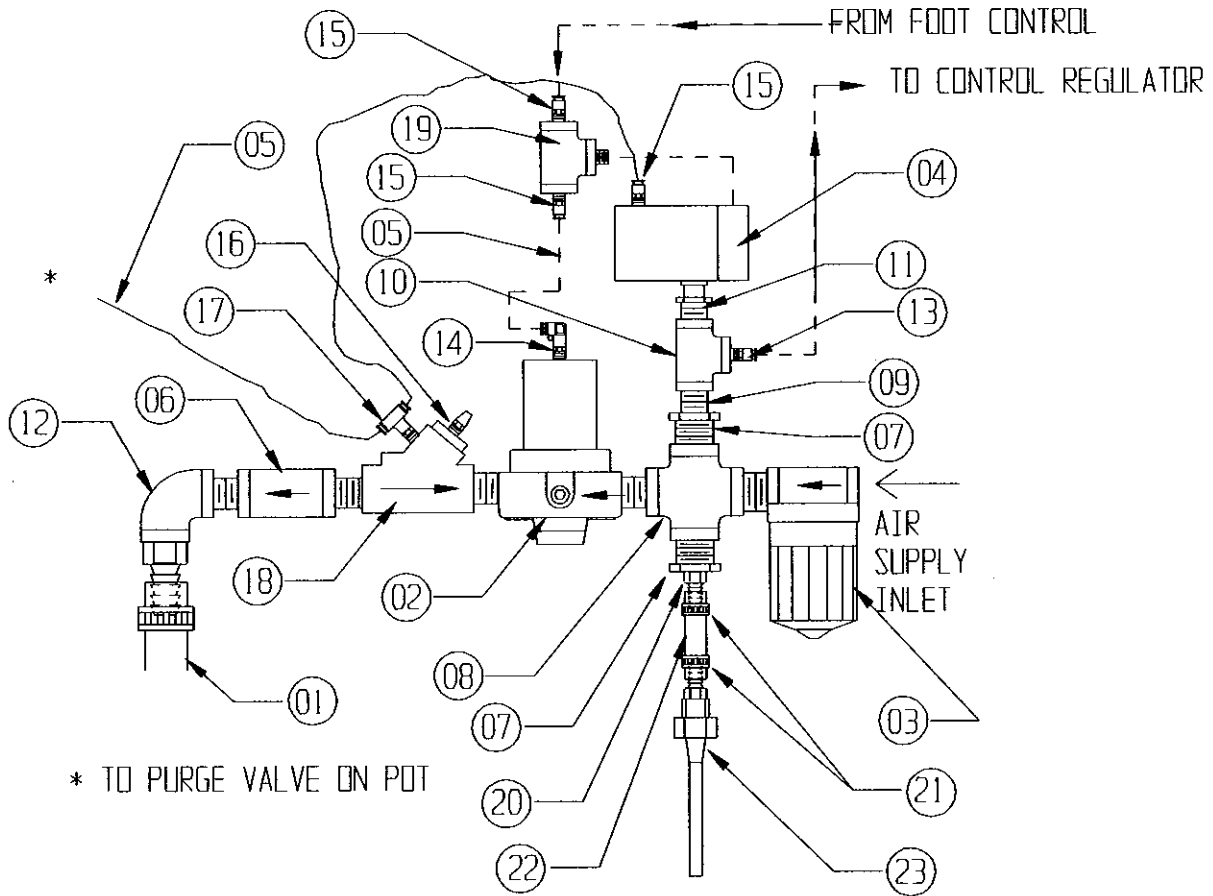

ITEM NO.	PART NO.	DESCRIPTION
1	18-080	HOSE, AIR 3/4" I.D.
2	16-896	REGULATOR, PILOT OPERATED 3/4" FPT.
3	16-897	AIR FILTER 3/4" FPT.
4	16-832	SOLENOID 3-PORT AIR/SPRING
5	18-111	TUBING 1/4" D.O. VINYL
6	006271	VALVE, CHECK IN-LINE
7	14-396	BUSHING, 3/4" x 1/4" (2)
8	14-516	CROSS, 3/4"
9	14-320	NIPPLE, 1/4" CLOSE
10	14-329	TEE, 1/4" BRASS
11	14-389	BUSHING, 1/4" x 1/8"
12	14-456	STREET ELL, 3/4"
13	004623	FITTING, STRAIGHT CONNECTOR 1/4" x 1/4"
14	003083	FITTING, 90° ELBOW CONNECTOR 1/4" x 1/4"
15	16-951	FITTING, STRAIGHT CONNECTOR 1/8" x 1/4"
16	000983	MUFFLER, 1/8"
17	16-950	TEE, RUNNING, 1/4 x 1/4 x 1/8
18	14-157	VALVE, AIR 3/4"
19	14-326	TEE, 1/8"
20	14-313	FITTING, 1/4"
21	21030	CLAMP
22	000738	HOSE, 1/4"
23	16-822	BLOW OFF NOZZLE

B2129

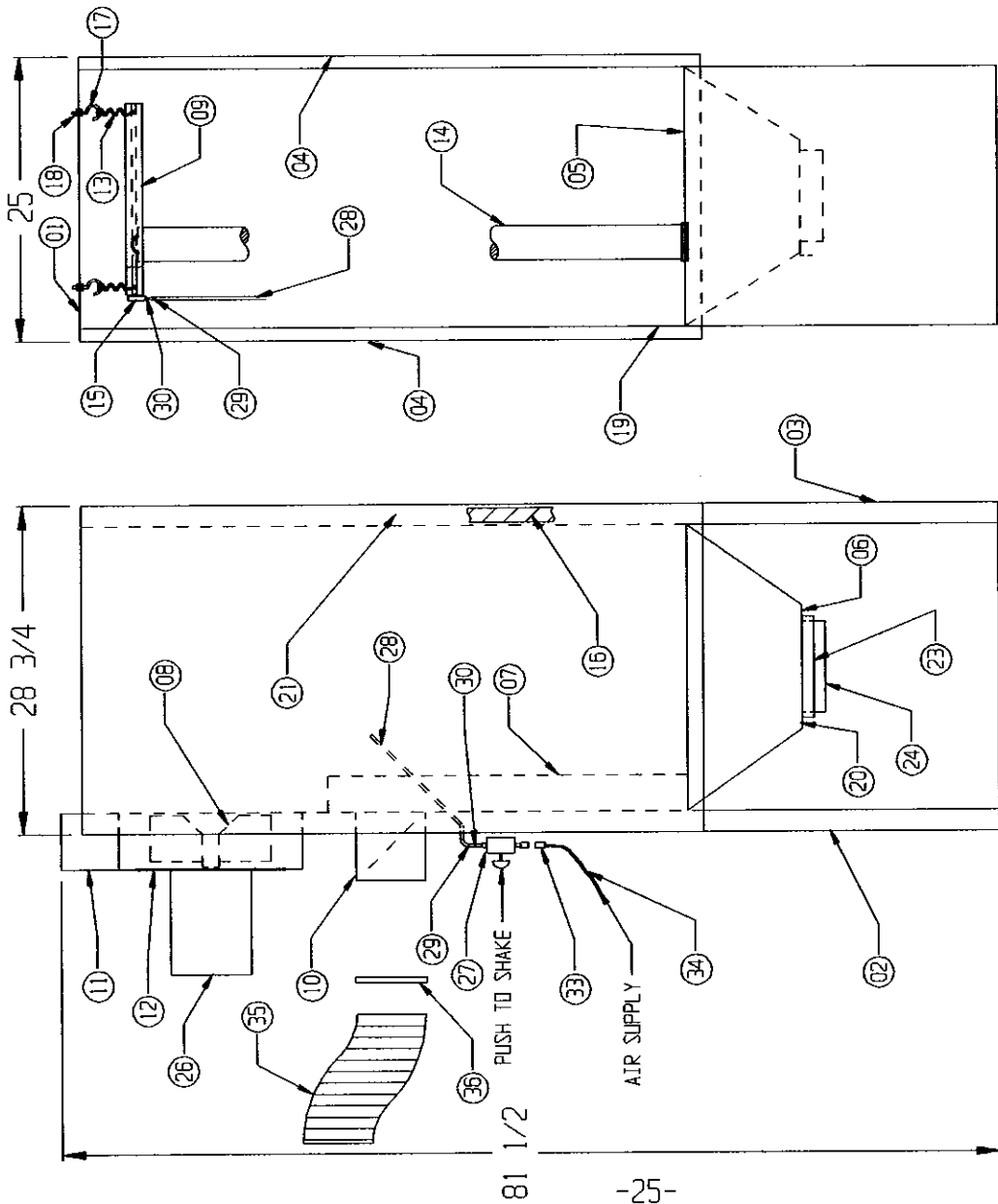

ITEM NO.	QTY.	DESCRIPTION	ENG. NO. / MATERIAL
38			
37			
36	2	SCREEN CLAMP	21-036
35	5'	FLEX HOSE (6")	19-096
34	6'	1/4" PLASTIC HOSE	18-111
33	1	MALE CONNECTOR	000718
32			
31			
30	2	1/8" x 1/4" HOSE BARB	14-316
29	2	1/4" SCREEN CLAMPS	21-030
28	3'	1/4" AIR HOSE	18-074
27	1	SHAKER VALVE 1/8"	16-830
26	1	MOTOR 1HP-110V 50C	13-700
25			
24	1	OUTLET FLANGE 8" DIA.	000725
23	1	SLIDE GATE	000324
22			
21	6	1/4" WING NUT	000305
20	80	1/4" x 3/4" LG. ROLLER	000301
19	12	1/4" x 1" LG. ROLLER	000377
18	8	3/16" HEX NUT	000378
17	4	3/16" EYE BOLT	000379
16	50'	1/4" x 1" GASKET	000307
15	1	SHAKER	16-919
14	25	DUST BAG	11-349
13	4	SPRING	000347
12	1	BLOWER/MOTOR PLATE	11-720
11	1	BLOWER HOUSING ASS'Y.	11-716
10	1	INLET DAMPER ASS'Y. (6" DIA.)	000723
09	1	DUST BAG MOUNT ASS'Y.	A2501
08	1	BLADE ASS'Y.	11-718
07	1	D-10 PLENUM ASS'Y.	000335
06	1	SPACER	000329
05	1	SUMP ASS'Y.	A2500
04	2	ODOR PANEL	A2466
03	1	RIGHT SIDE PANEL	A2465-1
02	1	LEFT SIDE PANEL	A2464-1
01	1	TOP PLATE	A2467-1

LARRY HESS & ASSOCIATES, INC.
SALTSBURY, NORTH CAROLINA

DESCRIPTION:		D-10 DUST COLLECTOR ASS'Y.		MATERIAL:		PER DWG.	
DATE:	BY:	DATE:	BY:	DATE:	BY:	DATE:	BY:
02/10/95	3/27/97	08/16/90	3/27/97	08/16/90	3/27/97	08/16/90	3/27/97
REV.	REV.	REV.	REV.	REV.	REV.	REV.	REV.
01	01	01	01	01	01	01	01
DRAWING NO.: B2129							

B2131

38				
37				
36	2	SCREW CLAMP (8")		21-038
35	8	FLEX HOSE (8")		19-088
34	6'	1/4" PLASTIC HOSE		18-111
33		MALE CONNECTOR		000718
32	1	FLEX HOSE (7")		19-087
31	1	HEPA BOX (OPTIONAL)		A35025
30	2	1/8" x 1/4" HOSE BARB		14-316
29	2	1/4" SCREW CLAMPS		000496
28	3'	1/4" AIR HOSE		18-074
27	1	SHAKER VALVE 1/8"		16-830
26	1	MOTOR 2HP-220/440V 3PH		13-900
25	2	SCREW CLAMP (7")		21-037
24	1	OUTLET FLANGE 8" DIA.		000725
23	1	SLIDE GATE		000324
22	1	HEPA FILTER		006588
21	6	1/4" WING NUT		000305
20	80	1/4" x 3/4" LG. ROLLOX		000301
19	12	1/4" x 1" LG. ROLLOX		000377
18	12	3/16" HEX NUT		000378
17	6	3/16" EYE BOLT		000379
16	50'	1/4" x 1" GASKET		000307
15	1	SHAKER		16-919
14	49	DUST BAG		11-349
13	6	SPRING		000347
12	1	BLOWER/MOTOR PLATE		11-920
11	1	BLOWER HOUSING ASS'Y.		11-916
10	1	INLET DAMPER ASS'Y. (8" DIA.)		001046
09	1	DUST BAG MOUNT ASS'Y.		A2507
08	1	BLADE ASS'Y.		11-718
07	1	D-20 PLENUM ASS'Y.		001051
06	1	SPACER		000329
05	1	SUMP ASS'Y.		A2506
04	2	DOOR PANEL		A2492
03	1	RIGHT SIDE PANEL		A2495
02	1	LEFT SIDE PANEL		A2496
01	1	TOP PLATE		A2494

ITEM NO. QTY. DESCRIPTION DWG. NO./ MATERIAL

LARRY HESS & ASSOCIATES, INC.
SALISBURY, NORTH CAROLINA

DESCRIPTION: D-20 DUST COLLECTOR ASS'Y. PER DWG.

MATERIAL:

DATE DEC 07/22/95	SCALE 5/8"=1'	SHEET NO. 11	DRAWING NO. B2131
BY J.B.	DATE 07/17/95		

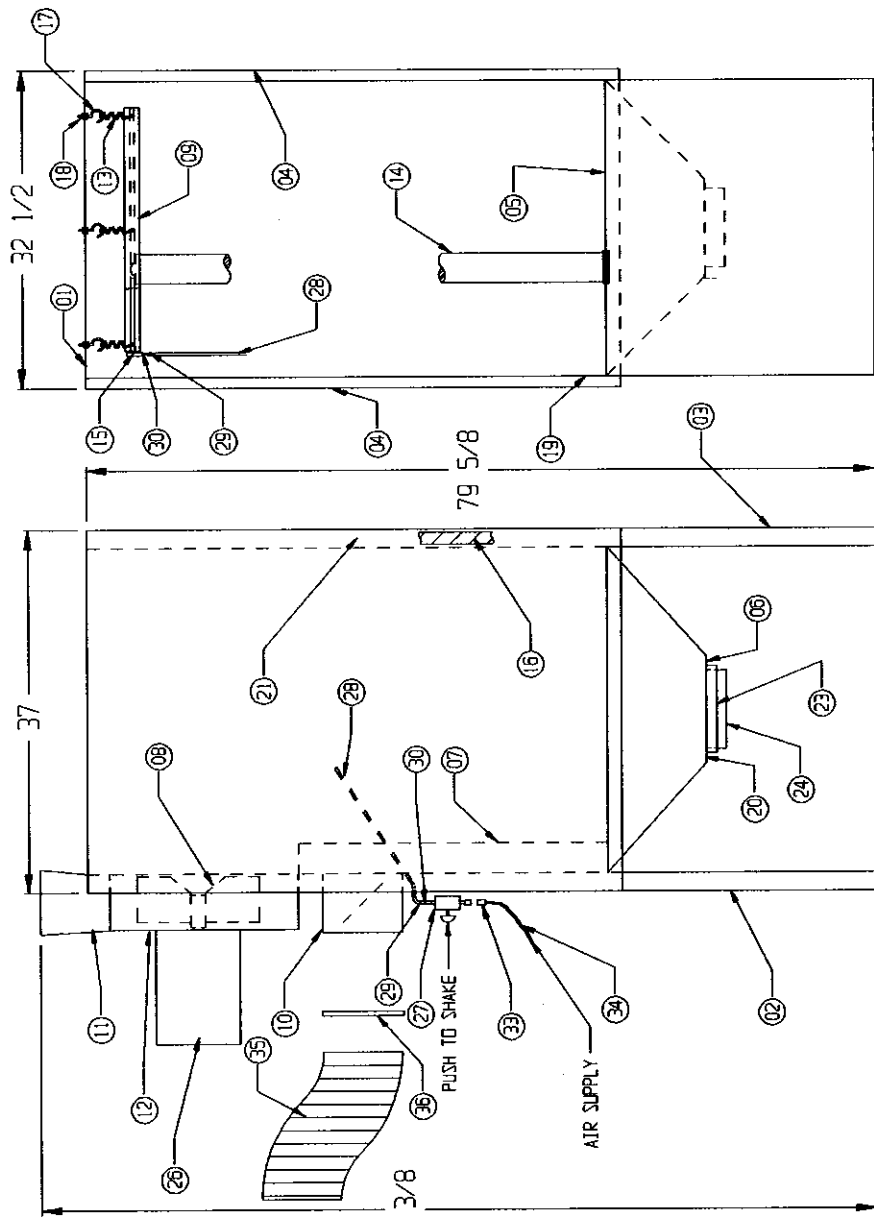

LARRY HESS & ASSOCIATES
 DESCRIPTION 120 V/ 1 PHASE ELECTRICAL SCHEMATIC
 DATE 4/23/96
 ENGINEER DEC
 DWG. NO. A5107

REV. 03/02/05 BY DEC

120 VOLT SINGLE PHASE WIRING

WHITE (NEUTRAL)

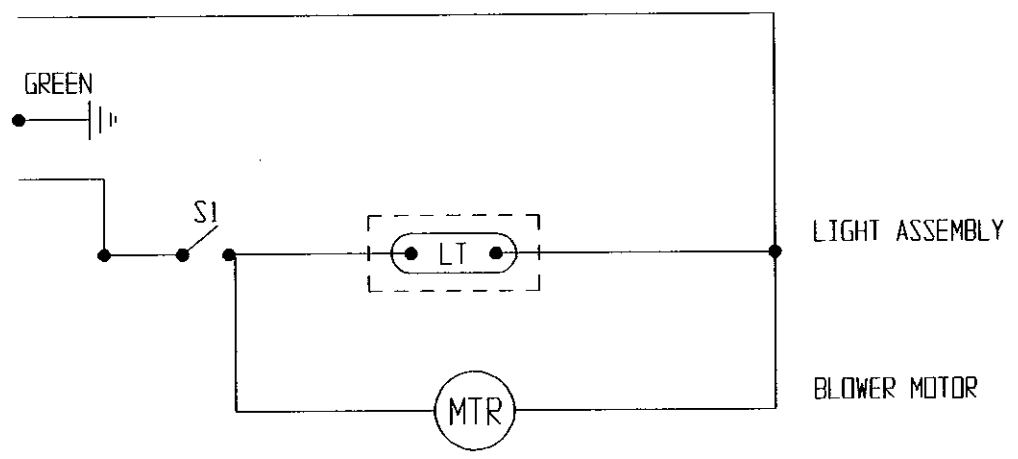

SWITCH NO.	FUNCTION	PART NO.
SW1	MACHINE LIGHT - OFF/ ON	13-655
LT	LIGHT FIXTURE	13-533
MTR	MOTOR (1 HP SINGLE PHASE)	13-700
MTR	MOTOR (1/2 HP SINGLE PHASE)	13-400

REV. 03/02/05 BY DEC

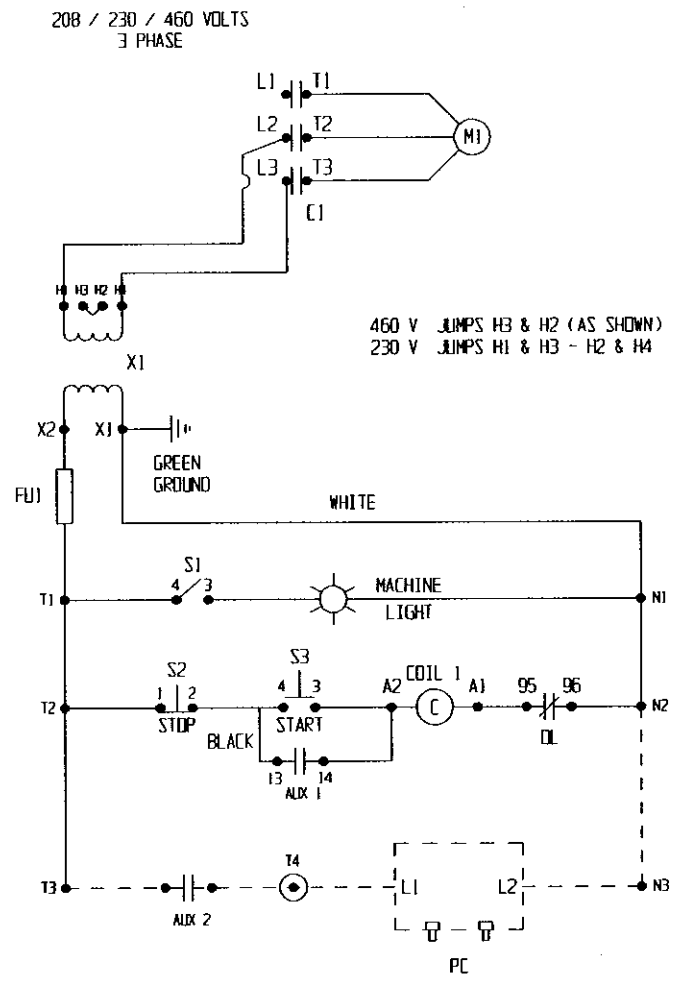

SWITCH NO.	FUNCTION	PART NO.
S1	MACHINE LIGHT - OFF/ ON	13-655
S2	M1 (PUSH TO STOP)	
S3	M1 (PUSH TO START) STARTS M1	006404
X1	TRANSFORMER (250)	000117
FU1	FUSE	13-101-5A
FH	FUSE HOLDER	13-101
C1	CONTACTOR	010210-S
OL	OVERLOAD (230 V)	010223-S
OL	OVERLOAD (460 V)	010211-S
M1	MOTOR (2 HP)	13-900
PC	PULSE CONTROL BOARD (RPJ ONLY)	010453
AUX 1	AUXILLARY CONTACT	011720

WARRANTY

Larry Hess & Associates, Inc. Warrants to the original purchaser the merchandise sold to be free from defects in material and workmanship under normal use and service for a period of one (1) year. Upon prompt notification by the buyer, to LHA, components that are determined by LHA to be defective will be repaired or replaced at no additional charge, F.O.B. our factory.

Manufacturer shall have the right to inspect prior to replacing all merchandise in question.

This warranty does not apply to parts that are directly involved in the blasting operation. Example: gun, gun parts, viewing window, hose, gloves, etc.

Manufacturer shall not be required to pay any removal or installation charges whatsoever under this warranty.

Manufacturer shall not be liable for prospective profits, special or consequential damages, nor shall any recovery of any kind against manufacturer be greater in amount than the cost of repairs of defects in workmanship.

This warranty does not apply to damage caused by accidents, damage in transit, alterations by unauthorized personnel, abuse or damage by flood, fire, or acts of God, nor by artificially generated electric currents or any other cause whatsoever except defects in material or factory workmanship.

In all cases, defective parts must be returned to Larry Hess & Associates, Inc. before credit is issued.

If genuine BLAST-IT-ALL® replacement parts are not used, the warranty is void.

This warranty is in lieu of all other warranties expressed or implied and releases Larry Hess & Associates, Inc. of all other obligations and liabilities whatsoever. This warranty neither assumes nor authorizes any person to assume any obligation other than those specified by this warranty.

WARNING

DO NOT USE SAND. SAND WILL CAUSE SILICA DUST, WHICH IS THE CAUSE OF SILICOSIS DISEASE, A CONDITION OF MASSIVE FIBROSIS OF THE LUNGS. THIS STATEMENT INDICATES POTENTIAL PERSONNEL HAZARD. FAILURE TO COMPLY WITH THESE INSTRUCTIONS MAY RESULT IN PERSONAL INJURY.

BLAST-IT-ALL®
Larry Hess & Associates, Inc.
Airport Industrial Park
185 Piper Lane
P.O. Box 1615
Salisbury, NC 28145-1615