



BLAST-IT-ALL®  
LEADING THE INDUSTRY IN  
SURFACE PREPARATION  
EQUIPMENT

**HESS MANUFACTURING, INC.**

*185 Piper Ln.  
Salisbury, NC 28147  
(800) 535-2612*

 *LIVE CHAT- [www.blast-it-all.com](http://www.blast-it-all.com)*



MANUAL DOWNLOAD

LITTLE BLASTER™  
OYSTER SHELL  
w/ DUST COLLECTOR

*Man. # 562\_v02-02*



*[www.blast-it-all.com](http://www.blast-it-all.com)*









**\*\* WARNING \*\***

**DO NOT USE SAND.** SAND WILL CAUSE SILICA DUST, WHICH IS THE CAUSE OF SILICOSIS DISEASE, A CONDITION OF MASSIVE FIBROSIS OF THE LUNGS. THIS STATEMENT INDICATES A POTENTIAL PERSONNEL HAZARD. FAILURE TO COMPLY WITH THESE INSTRUCTIONS MAY RESULT IN PERSONAL INJURY.

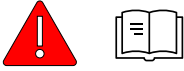

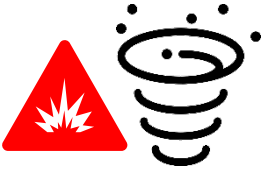



## Table of Contents

<b>SAFETY</b> .....	3
<i>OSHA FACT SHEET</i> .....	5
<b>INSTALATION :</b> .....	9
<i>LITTLE BLASTER w/CARTRIDGE DUST COLLECTOR</i> .....	9
<i>Little Blaster™ AIR CONTROLS</i> .....	11
<b>OPERATION</b> .....	14
<i>Little Blaster™</i> .....	14
<i>Little Blaster™ CARTRIDGE DUST COLLECTOR</i> .....	15
<b>TROUBLESHOOTING</b> .....	17
<b>MAINTENANCE</b> .....	18
<b>VENTURI BLAST GUN TUNING :</b> .....	19
<b>PARTS :</b> .....	20
<i>Little Blaster™ BLAST GUN ASSEMBLY PARTS</i> .....	20
<i>Little Blaster™ OYSTER SHELL CABINET PARTS</i> .....	21
<i>Little Blaster™ OYSTER SHELL MODELS</i> .....	22
<i>Little Blaster™ LIGHT BOX PARTS</i> .....	23
<i>Little Blaster™ MACHINE AIR CONTROL PARTS</i> .....	24
<i>Little Blaster™ CARTRIDGE DUST COLLECTOR PARTS</i> .....	25
<i>Little Blaster™ RECOMMENDED CONSUMABLE/SPARE PARTS</i> .....	26
<b>ELECTRICAL</b> .....	27
<i>Little Blaster™ Electrical Diagram</i> .....	27
<b>WARRANTY</b> .....	28
<b>VENTURI BLAST DATA</b> .....	29
<b>INDEX</b> .....	30

## SAFETY

	<p><b>*** READ ENTIRE MANUAL BEFORE INSTALATION/OPERATING EQUIPMENT ***</b></p>
	<p>1. <b>DO NOT USE SAND</b> SAND WILL CAUSE SILICA DUST, WHICH IS THE CAUSE OF SILICOSIS DISEASE, A CONDITION OF MASSIVE FIBROSIS OF THE LUNGS. THIS STATEMENT INDICATES A POTENTIAL PERSONNEL HAZARD. FAILURE TO COMPLY WITH THESE INSTRUCTIONS MAY RESULT IN PERSONAL INJURY.</p>
	<p>2. <b>(COLLECTED DUST)</b> THE CUSTOMER (END USER) ASSUMES THE RESPONSIBILITY FOR CONTACTING THEIR INSURANCE UNDERWRITER AND ADVISING HESS AND ASSOCIATES, INC. IN REGARD TO SPECIFIC APPLICATION REQUIREMENTS OF EXPLOSION VENTING OR IF ADDITIONAL FIRE PROTECTION AND SAFETY EQUIPMENT MAY BE REQUIRED. THE BUYER (END USER) IS ALSO CAUTIONED TO ADHERE TO PRESCRIBED OSHA, NFPA, FEDERAL, STATE, AND LOCAL CODES AND REGULATIONS APPLICABLE TO INDUSTRIAL VENTILATION SYSTEMS, WHICH HESS AND ASSOCIATES, INC. EQUIPMENT MAY BE APPLIED ON.</p>
	<p>3. HEARING PROTECTION IS RECOMMENDED WHILE OPERATING MACHINE</p>
	<p>4. EYE PROTECTION IS RECOMMENDED WHILE OPERATING MACHINE</p>
	<p>5. Machine <b>MUST</b> be properly Grounded</p>

SAFETY (cont'd)

 	<p>6. Gun MUST ALWAYS be pointed away from the Operator and Towards the item being processed.</p>
 	<p>7. NEVER Blast with ANY Doors OPEN. NO ONE Should be in Front of the Operating Station at the Front of the Blast Cabinet while Loading or Unloading Parts. DO NOT OPEN ANY DOOR WHILE THE MACHINE IS IN OPERATION</p>
 	<p>8. <b>DO NOT</b> CONNECT TO HIGH PRESSURE BOTTLE GAS, RUPTURE AND/OR EXPLOSION CAN OCCUR.</p>

## Protecting Workers from the Hazards of Abrasive Blasting Materials

Abrasive blasting uses compressed air or water to direct a high velocity stream of an abrasive material to clean an object or surface, remove burrs, apply a texture, or prepare a surface for the application of paint or other type of coating. Employers must protect workers from hazardous dust levels and toxic metals that may be generated from both the blasting material and the underlying substrate and coatings being blasted. This fact sheet provides information on abrasive blasting material, health hazards, and methods to protect workers.

### Abrasive Blasting Materials

The decision to use a certain type of abrasive material can depend on factors such as cost, job specifications, environment, and worker health.

Commonly used abrasive materials:

- Silica sand (crystalline)
- Coal slag
- Garnet sand
- Nickel slag
- Copper slag
- Glass (beads or crushed)
- Steel shot
- Steel grit
- Specular hematite (iron ore)

Alternative, less toxic blasting materials include:

- Ice cubes
- Dry ice
- Plastic bead media
- Sponge
- Sodium bicarbonate (baking soda)



Abrasive blasting creates high levels of dust. Photo courtesy

- Ground walnut shells, ground corn cob and other biodegradable materials
- High pressure water

#### \*\*\*\* CAUTION \*\*\*\*

Abrasive blasting creates high levels of noise that can cause substantial hearing loss. Always wear hearing protection. Employers must administer a hearing conservation program as required by the OSHA [Occupational Noise standard](#).

### Health Hazards

Abrasive blasting operations can create high levels of dust and noise. Abrasive material and the surface being blasted may contain toxic materials (e.g., lead paint, silica) that are hazardous to workers.

- Silica sand (crystalline) can cause silicosis, lung cancer, and breathing problems in exposed workers.
- Coal slag and garnet sand may cause lung damage similar to silica sand (based on preliminary animal testing).
- Copper slag, nickel slag, and glass (crushed or beads) also have the potential to cause lung damage.
- Steel grit and shot have less potential to cause lung damage.
- Slags can contain trace amounts of toxic metals such as arsenic, beryllium, and cadmium.

## How to Protect Workers from Exposure to Abrasive Blasting Materials

Each abrasive blasting operation is unique, involving different surfaces, coatings, blast material, and working conditions. Before beginning work, employers should identify the hazards and assign a knowledgeable person trained to recognize hazards and with the authority to quickly take corrective action to eliminate them. Use engineering and administrative controls, personal protective equipment (PPE), including respiratory protection, and training to protect workers involved in abrasive blasting activities. Engineering controls, such as substitution, isolation, containment, and ventilation are the primary means of preventing or reducing exposures to airborne hazards during abrasive blasting operations. Administrative controls, including the use of good work and personal hygiene practices, can also reduce exposure. When engineering and administrative controls cannot keep exposures to hazardous materials below OSHA permissible exposure limits, respiratory protection must be used.



Abrasive blasting using a dust collection system with multiple exhaust ducts. (Photo courtesy of Flexaust, Inc. This equipment is shown for illustrative purposes only and is not intended as an endorsement by OSHA of this company, its products or services.)

## Engineering Controls

### 1. Substitution

- Use a less toxic abrasive blasting material.
- Use abrasives that can be delivered with water (slurry) to reduce dust.

### 2. Isolation and Containment

- Use barriers and curtain walls to isolate the blasting operation from other workers.
- Use blast rooms or blast cabinets for smaller operations.
- Use restricted areas for non-enclosed blasting operations.
- Keep coworkers away from the blaster.

### 3. Ventilation

- Use exhaust ventilation systems in containment structures to capture dust.

Employers can use OSHA's free [On-site Consultation Program](#) for advice on safety and health issues.

## Administrative Controls

Perform routine cleanup using wet methods or HEPA filtered vacuuming to minimize the accumulation of toxic dusts.

- Do not use compressed air to clean as this will create dust in the air.
- Clean and decontaminate tarps and other equipment on the worksite.
- Schedule blasting when the least number of workers are at the site.
- Avoid blasting in windy conditions to prevent the spread of any hazardous materials.

## Personal Hygiene Practices

- Prohibit eating, drinking, or using tobacco products in blasting areas.
- Provide wash stations so workers can wash their hands and face routinely and before eating, drinking, or smoking.
- Vacuum or remove contaminated work clothes before eating, drinking or smoking.

- Provide accommodations for end-of-shift showers and change areas with separate storage facilities for street clothes, protective clothing and equipment.
- Keep contaminated clothing and equipment out of the clean change area.

### Respiratory Protection

An abrasive-blasting respirator must cover the wearer’s head, neck, and shoulders to protect the wearer from rebounding abrasive. Workers must use only respirators approved by [NIOSH](#) to provide protection from dusts produced during abrasive-blasting operations.

- Type CE NIOSH-certified blasting airline respirator with positive pressure blasting helmet.

Support personnel involved in cleanup and other related activities may also need respiratory protection.

When respirators are used, employers must establish a comprehensive respiratory protection program as required by the [OSHA Respiratory Protection standard \(29 CFR 1910.134\)](#).

### Personal Protective Equipment

- Hearing protection
- Eye and face protection
- Helmet
- Leather gloves that protect to full forearm and aprons (or coveralls)
- Safety shoes or boots

### Worker Training and Hazard Communication

- Provide training to abrasive blasters and support personnel on blasting health and safety hazards, how to use controls, personal hygiene practices, safe work practices and the use of PPE and respirators.
- Manufacturers are required to include appropriate health hazard information on the blasting materials on safety data sheets (SDS) as required under OSHA’s Hazard Communication standard ([29 CFR 1910.1200](#)).
- Obtain and read the manufacturer’s SDS for health hazard information on the abrasive blasting material you are using.

For more information on abrasive blasting and control measures see: OSHA’s guidance document: [“Abrasive Blasting Hazards in Shipyard Employment” \(2006\)](#); and [eTool: Mechanical Removers \(Ship Repair\)](#).

*Disclaimer: This OSHA Fact Sheet provides a general overview of the requirements in OSHA standards related to abrasive blasting. It does not alter or determine compliance responsibilities in these standards or the Occupational Safety and Health Act of 1970. Since interpretations and enforcement policy may change over time, the reader should consult current OSHA interpretations and decisions by the Occupational Safety and Health Review Commission and the courts for additional guidance on OSHA compliance requirements.*

**This is one in a series of informational fact sheets highlighting OSHA programs, policies or standards. It does not impose any new compliance requirements. For a comprehensive list of compliance requirements of OSHA standards or regulations, refer to Title 29 of the Code of Federal Regulations. This information will be made available to sensory-impaired individuals upon request. The voice phone is (202) 693-1999; teletypewriter (TTY) number: (877) 889-5627.**

**For assistance, contact us. We can help. It’s confidential.**



**www.osha.gov (800) 321-OSHA (6742)**



U.S. Department of Labor

DSG FS-3697 09/2014

## Applicable OSHA Standards and Safety and Health Topic Pages









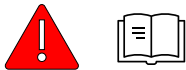

The following table provides links to several OSHA standards (not all-inclusive) that may contain requirements that apply to abrasive blasting operations. For example, the removal of lead paint by abrasive blasting will likely require employers to follow provisions of the OSHA Lead standard. Safety and health topic pages listed here provide employers and workers with information that may be useful for safely conducting abrasive blasting.

General Industry	Shipyards Industry	Construction Industry	OSHA Topics Page(s)
1910.94, Ventilation	1915.33 & 1915.34, Chemical & Mechanical paint removers  Ventilation (as it applies to shipyard employment, 1910.94)  1915.13, Cleaning and other cold work	1926.57, Ventilation	Ventilation
1910.95, Occupational noise exposure	1910.95, Occupational noise exposure (as per Shipyard "Tool Bag" Directive, CPL 02-00-182)	1926.52, Occupational noise exposure  1926.101, Hearing Protection	Noise
1910.132, Personal Protective Equipment	1915 Subpart I, Personal Protective Equipment	1926 Subpart E, Personal Protective Equipment	Personal Protective Equipment
Respiratory Protection (1910.134)	1915.154, Respiratory Protection refers to (1910.134)	1926.103, Respiratory Protection (refers to 1910.134)	Respiratory Protection
1910.141, Sanitation  1910.1000, Air contaminants  Table Z-1, Limits for air contaminants  Table Z-2, Toxic and Hazardous Substances  Table Z-3, Mineral dusts	1915.88, Sanitation  1915.1000, Air contaminants  Table Z – Shipyards	1926.51, Sanitation  1926.55, Gases, vapors, fumes, dusts, and mists  Appendix A, Threshold limit values of airborne contaminants for construction	Permissible Exposure Limits (PELs) & Hazardous and Toxic Substances
Beryllium See 1910.1000, Table Z-1 for air contaminants	Beryllium See 1915.1000, Table Z	Beryllium See Table 1926.55, Appendix A	Beryllium
Silica See 1910.1000, Table Z-3	Silica See 1915.1000, Table Z	Silica See 1926.55, Appendix A	Silica
1910.1018, Inorganic Arsenic	1915.1018, Inorganic Arsenic	1926.1118, Inorganic Arsenic	Arsenic
1910.1025, Lead	1915.1025, Lead	1926.62, Lead	Lead (General Industry) Lead (Construction)
1910.1026, Chromium(VI)	1915.1026, Chromium(VI)	1926.1126, Chromium(VI)	Hexavalent Chromium
1910.1027, Cadmium	1915.1027, Cadmium	1926.1127, Cadmium	Cadmium
1910.1200, Hazard Communication	1915.1200, Hazard Communication (refers to 1910.1200)	1926.59, Hazard Communication (refers to 1910.1200)	Hazard Communication

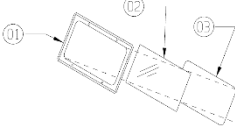

## INSTALLATION :

### LITTLE BLASTER w/CARTRIDGE DUST COLLECTOR

	<p><b>*** READ BEFORE OPERATING EQUIPMENT ***</b></p>
	<ol style="list-style-type: none"> <li>1. Remove all shipping protection. Remove shipping protection. Lift the Top Section JUST Enough to remove the Hardware and Rear Leg Supports. Install the Rear Legs Supports prior removing the Machine from the Pallet. Check for any concealed shipping damage, if discovered, report the damage to your freight carrier AS Non-Disclosed Hidden Damage immediately.</li> </ol>
	<ol style="list-style-type: none"> <li>2. Blast Cabinet should be placed in a desired location, away from any water or moist environment and Secured to the Floor. If moist compressed air is present at this location, install a good moisture separator.</li> </ol>
	<ol style="list-style-type: none"> <li>3. Install Air Controls (READ INSTALLATION –“ Little Blaster™ AIR CONTROLS”)</li> </ol>
	<ol style="list-style-type: none"> <li>4. Install Cartridge Dust Collector: Packaged with machine are bolts, washers, nuts and gasket material. Apply gasket to SIDE of cabinet around large hole, press to make a firm bond to cabinet and squeeze together at seam. Align the 4-hole bolt pattern of the Dust Collector and install bolts, washers, and nuts. Tighten bolts and nuts securely.</li> </ol>
	<ol style="list-style-type: none"> <li>1. Remove Window Frame/Window Glass and Install the Mylar Roll into the Mylar Dispenser. Pull Mylar from the Mylar Dispenser Across the Window Opening. Place the Window Glass/Window Frame on Top of the Mylar, Securing with Plastic Knobs.</li> </ol>
	<ol style="list-style-type: none"> <li>1. Install Gloves ( Watch the Video) </li> </ol>
	<ol style="list-style-type: none"> <li>2. Plug electrical cord from side of dust collector into plug from light box. (READ OPERATION - “Little Blaster™ CARTRIDGE DUST COLLECTOR”)</li> </ol>
	<ol style="list-style-type: none"> <li>3. Connect your air supply line to machine air inlet on left rear leg, we recommend using a minimum 1/2" I.D. Hose or Pipe supply line. (Again, make sure your air supply line is free from oil and moisture). (If not, install a good moisture separator). Part #: 16-815 (<b>DO NOT USE ANY QUICK DISCONNECT COUPLINGS</b>)</li> </ol>
	<ol style="list-style-type: none"> <li>4. Connect the electrical cord from light box to a grounded electrical source.  120-volt/60 cycle, single phase A 15 AMP breaker or fuse should be used. <b>MAKE SURE MACHINE HAS PROPER GROUND</b></li> </ol>



*LITTLE BLASTER w/CARTRIDGE DUST COLLECTOR (cont'd)*

	<p>5. Charge blast machine with abrasive. Pour media into the cabinet through one of the doors and fill to bottom of Access Door. Media Sold Separately @ <a href="#">Blast-It-All Online Store</a></p>
---	---

AGGREGATES

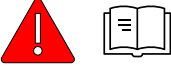
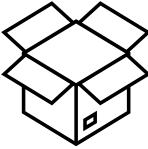

## INSTALLATION :

### Little Blaster™ AIR CONTROLS

	<p style="text-align: center;"><b>*** READ BEFORE OPERATING EQUIPMENT ***</b></p>
	<ol style="list-style-type: none"><li>1. Remove Box from inside of the Machine. Box contains :<ul style="list-style-type: none"><li>➤ Foot Petal, ½" Air Regulator w/Assembled Hoses</li><li>➤ Blast Gun w/Assembled Hose</li><li>➤ ½" Barbed Brass Fitting</li></ul></li></ol>
	<ol style="list-style-type: none"><li>2. Connect Air Regulator to the Bracket on the Front of the Machine w/Lock Ring</li></ol>
	<ol style="list-style-type: none"><li>3. Apply Teflon Tape to the ½" Barbed Brass Fitting and install to the to the Inside Left Leg of the Machine (Coupler). Attach/Secure Inlet Air Hose to the Barbed Brass Fitting.</li></ol>

## INSTALLATION :

### Little Blaster™ AIR CONTROLS (cont'd)

	<p>4. Insert Air Hose from the Foot Petal through the Rubber Grommet on the Right Side of the Sump.</p>
	<p>5. Remove Work Grate from inside of the Machine. Insert the Media Hose (attached to Gun) from the Inside, through the Rubber Grommet on the Back Sump. Replace the Work Grate, ensuring the hoses are routed through the Work Grate Opening.</p>
	<p>6. Attach/Secure Air Hose to the Back of the Blast Gun.</p>

## INSTALATION :









*Little Blaster™ AIR CONTROLS (cont'd)*



7. Teflon Tape and Attach the MEDIA VALVE to the Bottom of the Sump and Attach/Secure the Media Hose from the Back of the Sump to the Media Valve's Barbed Brass Fitting. ***Small Fitting Should Always be Facing Up an Remain Open.***

## OPERATION

Little Blaster™

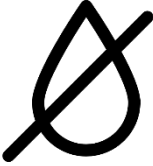
 	<p><b>*** READ BEFORE OPERATING EQUIPMENT ***</b></p>
	<p><b>1. Preparing Parts for Blasting :</b> All parts to be processed must be free of oil, grease, and moisture. Make sure parts are dry before putting into cabinet for processing.</p>
	<p><b>2. Air Pressure :</b> Set air pressure at 80 PSI. Most parts for blasting cleaning cabinet should be blasted at 80 PSI. Designate parts to be processed, start at lower pressure and work up the PSI scale to obtain desired finish.</p> <p><b>DO NOT</b> CONNECT TO HIGH PRESSURE BOTTLE GAS, RUPTURE AND EXPLOSION CAN OCCUR.</p>  
	<p><b>3. Gun Angle and Distance:</b> Direct blast at part with an approximate (45-60) degree angle with ricochet toward the back side of cabinet. Do not hold at 90 degree to part being processed. This will cause the media to blast to bounce back into the blast stream and slow blasting action. Also 90-degree angle will cause excessive wear on gun and viewing window. Hold gun approximately 6 inches from part being cleaned.</p> <p><b>GUN MUST ALWAYS BE POINTED AWAY FROM THE OPERATOR AND TOWARD ITEM BEING PROCESSED. NEVER BLAST WITH ANY OF THE CABINET DOORS OPEN. WHILE LOADING AND UNLOADING, NO ONE SHOULD BE AT THE OPERATOR STATION AT FRONT OF THE BLAST CABINET.</b></p> 
	<p><b>4. Media should be good quality and dry. Damp media will cause the media not to flow and will clog abrasive flow.</b></p> <p><b>IF YOU ARE HAVING A PROBLEM SELECTING MEDIA FOR A SPECIFIED JOB, CONTACT YOUR DISTRIBUTOR FOR THEIR RECOMMENDATIONS</b></p>

## OPERATION

### Little Blaster™ CARTRIDGE DUST COLLECTOR



**\*\*\* READ BEFORE OPERATING EQUIPMENT \*\*\***

After installing the Dust Collector, it is very IMPORTANT to follow the next steps. This will ensure your machine will blast satisfactorily and have good visibility in blast chamber.

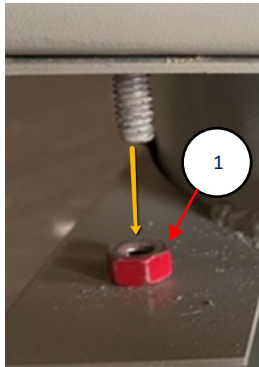



1. Remove **RED** nuts securing the motor housing and cartridge holder to dust collector body. (Item 1) Discard these nuts, they are not used.



2. Loosen nuts on back corners. Loosen until the nut is to the bottom on the bolt thread. This will allow the motor housing and cartridge holder to rest securely on the gasket seal.



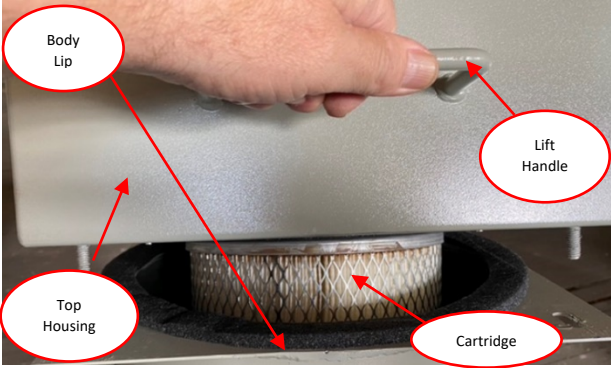

## OPERATION

### Little Blaster™ CARTRIDGE DUST COLLECTOR (cont'd)

	<p>3. To clean cartridge: Turn Dust Collector switch off. Grasp lift handle and raise up and down vigorously allowing the top housing to thump on the body lip. Do this repeatedly, until loose dust on the cartridge falls off into the dust sump. This should be done every 30 minutes of blasting, or each time before use. It is a good idea occasionally to remove motor housing and with <b>10-15 PSI</b> of airline pressure from air nozzle, blow the cartridge pleats clean.</p>
	<p>4. After thumping the cartridge, the drain cap should be removed and the <b>dust emptied</b> from dust collector sump into a box, bag or container, for ease of disposing.</p>
<p>Maintained properly, you will enjoy the performance of this reliable type dust collector.</p>	





## TROUBLESHOOTING

	<p><b>1. Caking of Media :</b></p> <p>A. Media caking is caused by moisture in compressed air supply or oily and greasy parts. If this is not corrected, media will not flow and will clog gun. Check air supply. If water or moisture is present, install a good moisture trap. If oily or greasy parts are being blast treated, you should first degrease and dry parts.</p> <p>B. If blast gun should occasionally clog, tightly seal the front of the nozzle against the inside front the blast cabinet and push foot valve down 3 to 4 seconds. This will cause the system to back blast through the gun and media hose and clear the media hose.</p>
	<p><b>2. Gun Air Pressure Drop :</b></p> <p>Set air regulator at <b>80 PSI</b> on air gauge. Push foot valve and if gauge reading should drop, check the air supply pipe or hose. A restriction in the supply line such as reducers or quick couplers will cause pressure drop. Also, if the blast cabinet is too far from the air compressor, a pressure drop can occur. We recommend 1/2" - 1" I.D. air supply line. The bigger the better.</p>
	<p><b>3. Poor Visibility - Excessive Dust :</b></p> <p>A. Cabinet Air inlet blocked, check for blockage.</p> <p>B. Dust collector sump full and needs emptied.</p> <p>C. Cartridge contaminated. Clean by pushing up and down.</p> <p>D. Media breakdown - replace media and clean dust collector.</p>
	<p><b>4. Poor Media Flow :</b></p> <p>A. Wet or damp media caused from moisture or oil in compressed air line. Use dry air or install a moisture filter.</p> <p>B. Replace media and clean media sump and hose.</p> <p>C. Media level should be below media screen.</p> <p>D. Hole in media hose from wear, replace hose assembly.</p> <p>E. Poor Air Flow/CFM</p> <p>F. Worn Gun Body, Nozzle or Orifice</p>

## MAINTENANCE

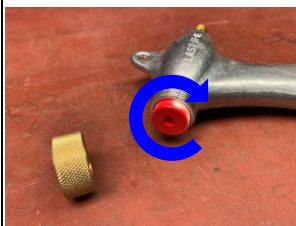

### Little Blaster™ MAINTENANCE INSTRUCTIONS

 	<b>*** READ BEFORE OPERATING EQUIPMENT ***</b>
---	--

	<p><b>5. Blasting Gun :</b> After 10 - 12 hours of blasting time the air orifice and nozzle should be checked. If the nozzle shows wear, rotate <b>1/4 Turn</b> to prevent uneven wear. If this is not checked, it could result in the destruction of nozzle and damage to the gun housing. If wear is detected on the orifice tip, replace.</p>
	<p><b>6. Gun Air Pressure Drop :</b> Set air regulator at <b>80 PSI</b> on air gauge. Push foot valve and if gauge reading should drop, check the air supply pipe or hose. A restriction in the supply line such as reducers or quick couplers will cause pressure drop. Also, if the blast cabinet is too far from the air compressor, a pressure drop can occur. We recommend 1/2" - 1" I.D. air supply line. The bigger the better.</p>
	<p><b>7. Poor Visibility - Excessive Dust :</b></p> <ul style="list-style-type: none"> <li>E. Cabinet Air inlet blocked, check for blockage.</li> <li>F. Dust collector sump full and needs emptied.</li> <li>G. Cartridge contaminated. Clean by pushing up and down.</li> <li>H. Media breakdown - replace media and clean dust collector.</li> </ul>

ITEM	DESCRIPTION	FREQUENCY
NOZZLES	INSPECT FOR WEAR	DAILY
MEDIA HOSE	INSPECT FOR WEAR / HOLES	MONTHLY
GUN BODY	INSPECT FOR WEAR	MONTHLY
GUN ORIFICE	INSPECT FOR WEAR	MONTHLY
MYLAR	INSPECT FOR POOR VISABILITY	PER USE
VIEW WINDOW	INSPECT FOR DAMAGE	PER USE
DUST / DEBRIS REMOVAL	REMOVE DUST / DEBRIS ACCUMULATION	PER USE
DUST BAGS	CLEAN	AS NEEDED
FLEX HOSE	INSPECT FOR WEAR / LEAKS	WEEKLY
GLOVES	INSPECT FOR WEAR / HOLES	WEEKLY
WEAR PLATES	INSPECT WEAR PLATE / LINERS FOR WEAR	MONTHLY

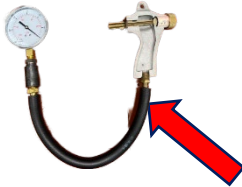
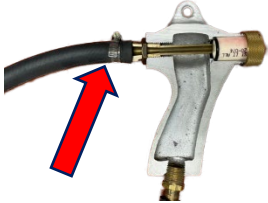
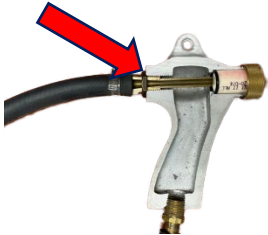
## VENTURI BLAST GUN TUNING :

	<p>WATCH THE VIDEO FROM BLAST-IT-ALL® <a href="https://www.youtube.com/watch?v=dKT9XeFhNNY">https://www.youtube.com/watch?v=dKT9XeFhNNY</a></p>
	<p>1. Attach &amp; Secure Vacuum Gage Hose to the Bottom of the gun.</p>
	<p>2. Attach &amp; Secure Compressed Air (80psi) Hose to the Orifice Inlet.</p>
	<p>3. Open Air Flow into the Orifice Inlet and Adjust the Orifice Inlet <i>IN</i> or <i>OUT</i> until 15 ~ 18 in Hg Vacuum is Achieved. Tighten Lock Nut to Maintain Position.</p>
	<p>4. When Range of Vacuum Can Not be Achieved, Part/Parts Replacement will be Required.</p>



*Little Blaster™*  
OYSTER SHELL CABINET PARTS

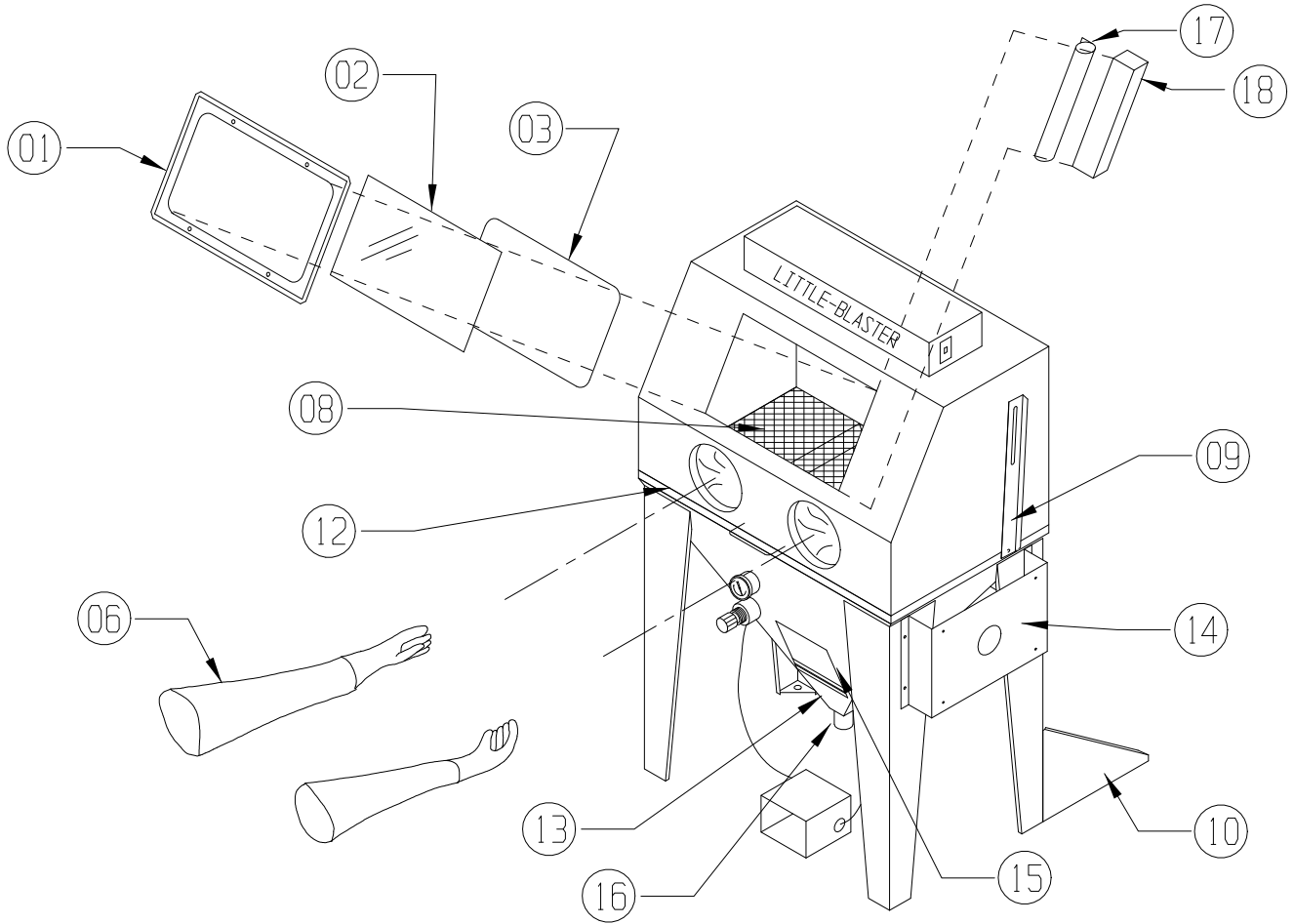

ITEM NO.	PART NO.	DESCRIPTION
1	23-053	WINDOW FRAME
2	23-050	WINDOW, VIEWING
3	24-054-64	WINDOW GASKET
4	-----	-----
5	-----	-----
6A	22-111	GLOVE, SNAP-IN (LEFT ONLY)
6B	22-112	GLOVE, SNAP-IN (RIGHT ONLY)
7	-----	-----
8	10-152-42	GRATE (LB 4224DS)
9	D112-23	TOP SLIDE LATCH
10	D112-25	LEG SUPPORT
11	15-720	DOOR CAM RUBBER GRIP
12	24-054-132	GASKET
13	10-050-42	SUMP SCREEN (LB 4224DS)
14	D112-24	DUST COLLECTOR OR RECLAIMER MOUNT
15	24-055	CLEAN OUT DOOR GASKET
16	20-200	MEDIA VALVE
17	011191	MYLAR GLASS PROTECTOR
18	011190	MYLAR HOLDER

Little Blaster™  
OYSTER SHELL MODELS

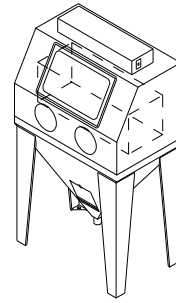
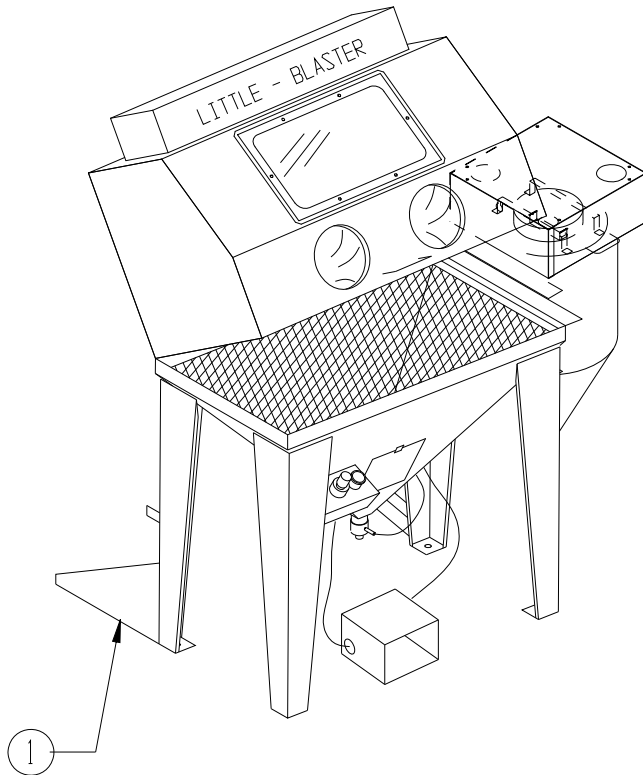
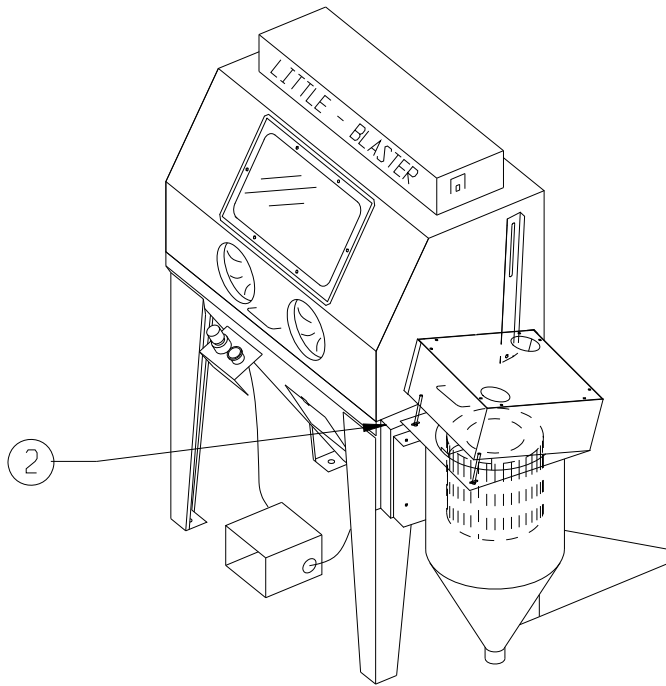

Fig. A

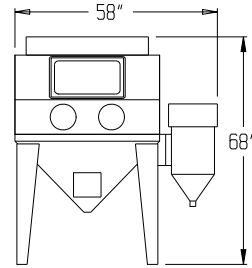

Fig. B

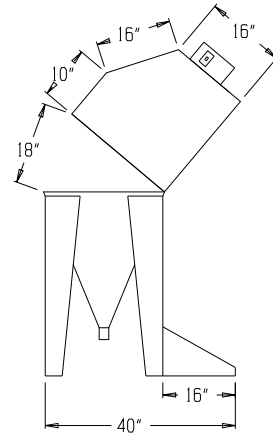

Fig. C

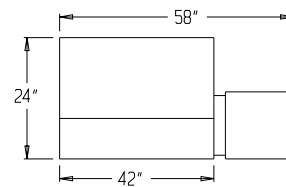
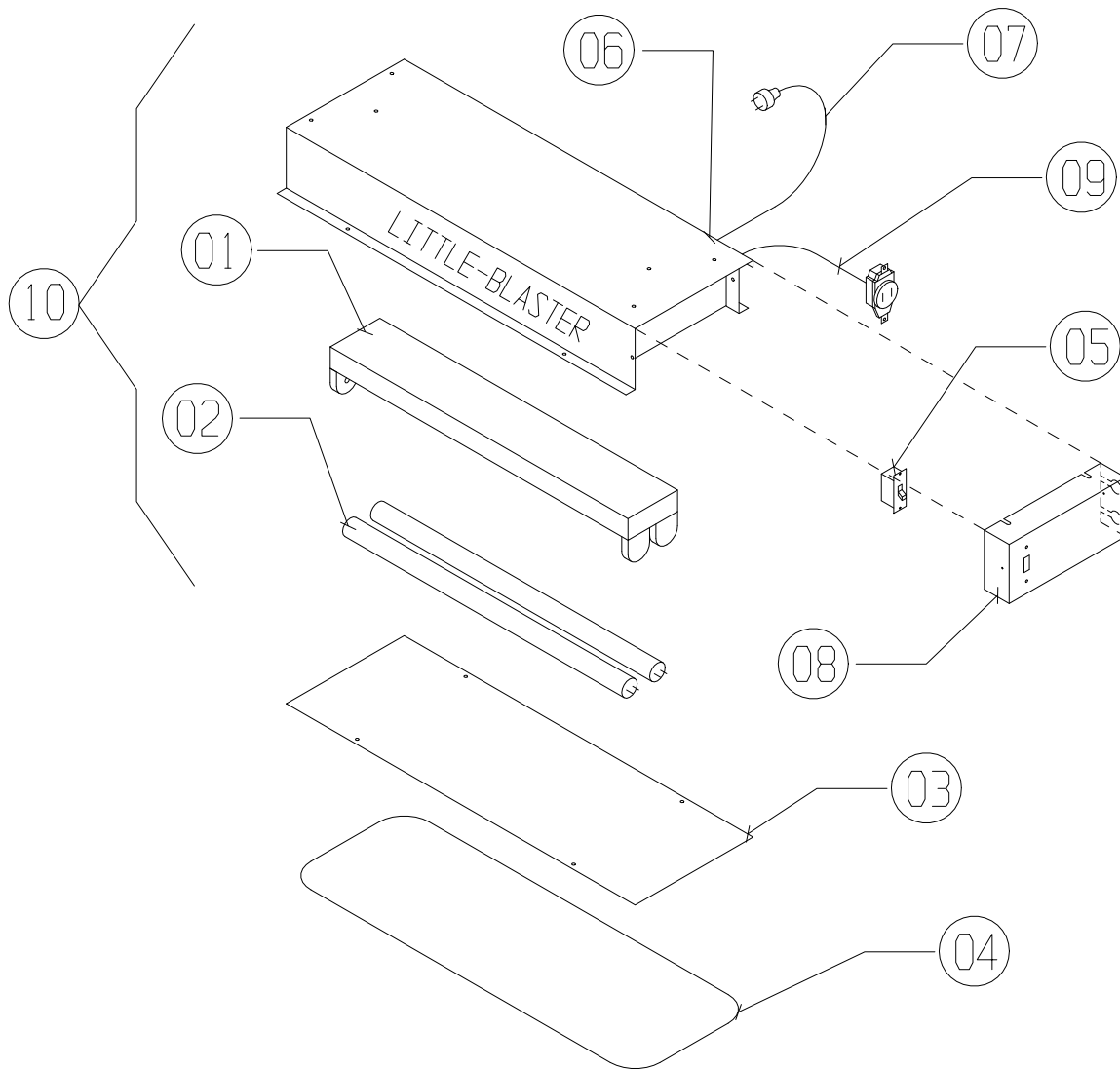

Fig. D

*Little Blaster™*  
LIGHT BOX PARTS



ITEM NO.	PART NO.	DESCRIPTION
1	13-533	FLUORESCENT FIXTURE, (NO TUBES)
2	13-534	24" FLUORESCENT TUBE
3	010216	PROTECTOR, LIGHT
4	24-054-64	WINDOW GASKET, 64" IN LENGTH
5	13-655	SWITCH
6	13-605	HEYCO CONNECTOR
7	13-550	POWER CORD, 3 WIRE
8	B198-2	SWITCH MOUNTING PLATE
9	13-616-1	FEMALE RECEPTACLE
10	010800 LBLTBX	COMPLETE LIGHT BOX (EXCEPT 3 & 4)

*Little Blaster™*  
MACHINE AIR CONTROL PARTS

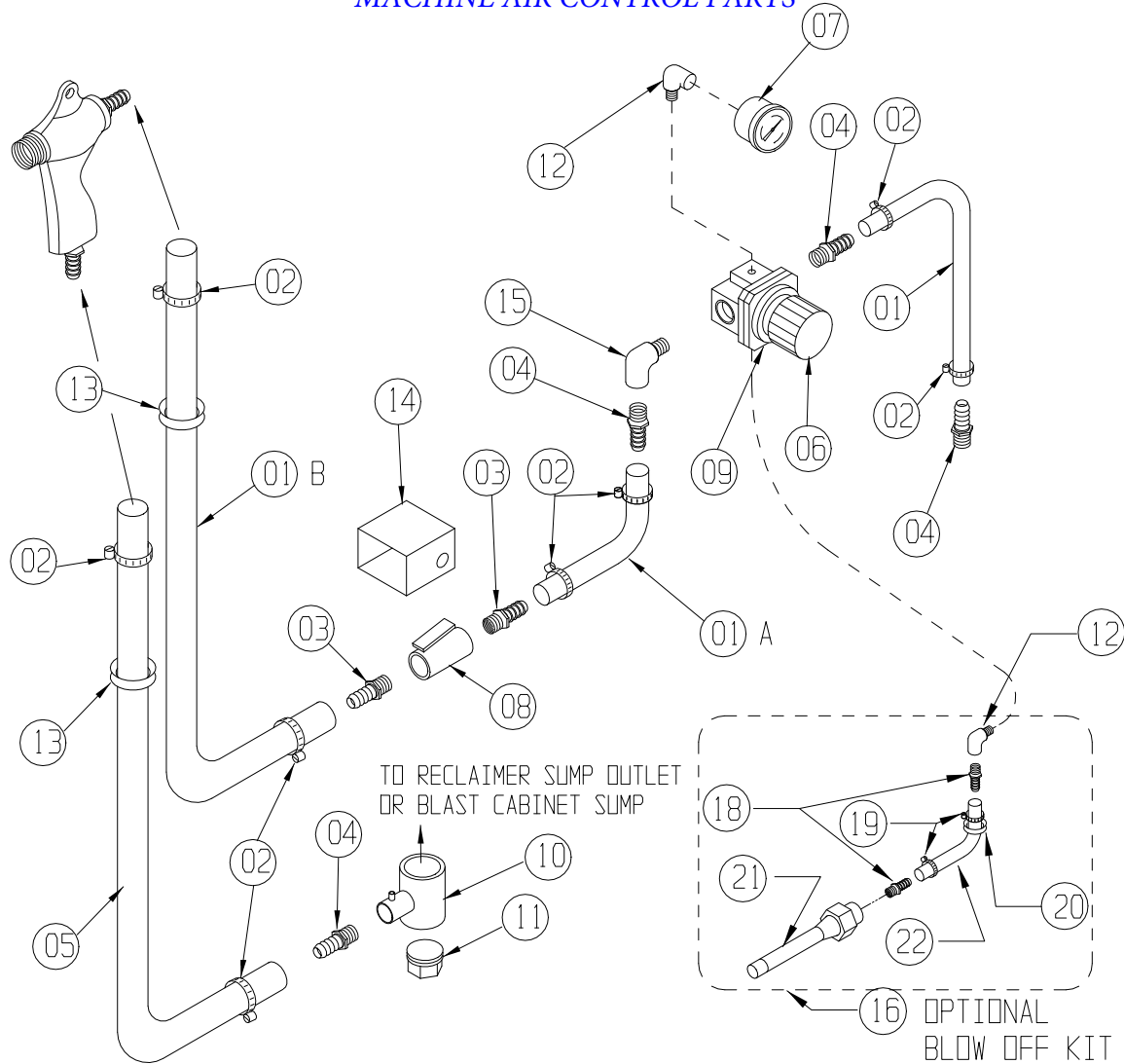

ITEM NO.	PART NO.	DESCRIPTION
1	18-076-2	HOSE, AIRLINE (2 FT.)
1A	18-076-3	HOSE, AIRLINE (3 FT.)
1B	18-076-7	HOSE, AIRLINE (7 FT.)
2	21-032	CLAMP, HOSE
3	14-302	FITTING, 1/2" HOSE x 3/8" MPT
4	14-301	FITTING, 1/2" HOSE x 1/2" MPT
5	18-084-6	HOSE, MEDIA LINE (6 FT.)
6	16-965	REGULATOR, AIR 1/2"
7	16-820	GAUGE, AIR
8	16-835	VALVE, AIR FOOT CONTROL ONLY
9	16-965LR	REGULATOR LOCK RING
10	20-200	MEDIA VALVE
11	20-201	PLUG (MEDIA VALVE)
12	002301	1/4" STREET ELL
13	24-050	GROMMET, HOSE
14	16-836	HOUSING, FOOT CONTROL ONLY (NO VALVE)
15	14-372	1/2" STREET ELL
16	009059	OPTIONAL BLOW OFF KIT
17	-----	-----
18	14-313	FITTING, 1/4 x 1/4 NPT
19	010412	CLAMP, 1/4" AIR HOSE
20	24-052	GROMMET
21	16-822	BLOW OFF NOZZLE
22	000738-6	HOSE, 1/4" AIR x 6' LONG



*Little Blaster™*  
**CARTRIDGE DUST COLLECTOR PARTS**

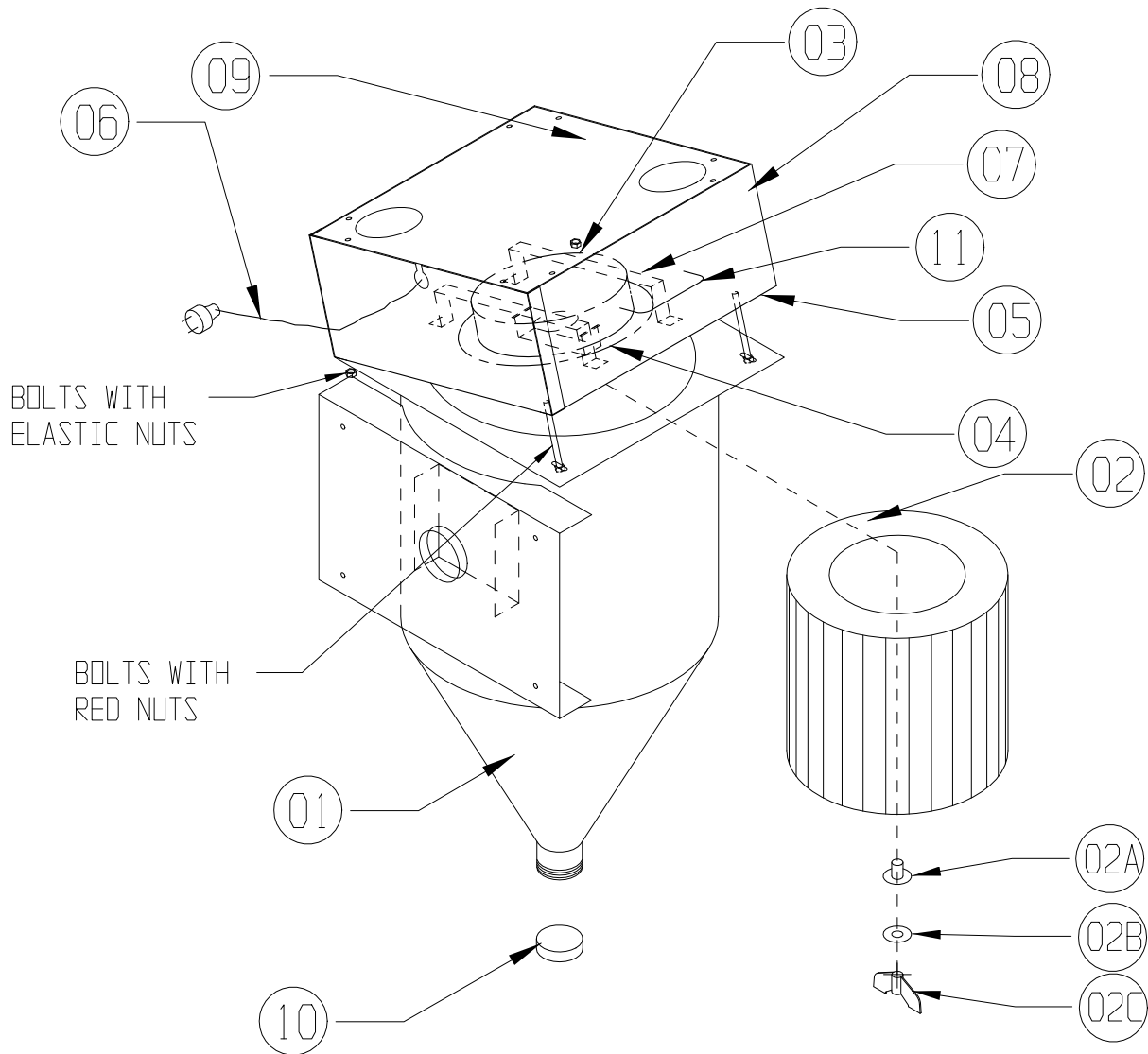

\*NOTE: ITEM (2A) RUBBER SEAL MUST BE IN PLACE TO REDUCE PREMATURE MOTOR FAILURE

ITEM NO.	PART NO.	DESCRIPTION
1	D2025	DUST COLLECTOR BODY
2	11-1524	DUST COLLECTOR CARTRIDGE ( INCLUDES 2A, 2B, 2C )
2A	11-1524S	RUBBER SEAL
2B	30-601	1/4" WASHER
2C	30-510	1/4" WING NUT
3	13-200	MOTOR, 120V, 60/50 Hz, 6.9 AMP
4	24-056	GASKET, MOTOR SEAL
5	24-054-48	GASKET, TOP SEALING
6	010172	CORD, MALE PLUG
7	D2025-09	MOTOR BRACKETS
8	D2025-05&06	MOTOR HOUSING
9	D2025-04	COVER PLATE
10	010217	2" PIPE CAP
11	-----	LIFT HANDLE

*Little Blaster™ RECOMMENDED CONSUMABLE/SPARE PARTS*

PART NO.	DESCRIPTION
23-050	WINDOW, VIEWING
22-111	GLOVE, SNAP-IN (LEFT ONLY)
22-112	GLOVE, SNAP-IN (RIGHT ONLY)
20-200	MEDIA VALVE
011191	MYLAR GLASS PROTECTOR
20-054	NOZZLE NUT HOLDING
20-074	NOZZLE CERAMIC, ¼" I.D. SIZE 4
20-075	NOZZLE CERAMIC, 5/16" I.D. SIZE 5
20-076	NOZZLE CERAMIC, 3/8" I.D. SIZE 6
20-084	NOZZLE CARBIDE, ¼" I.D. SIZE 4
20-085	NOZZLE CARBIDE, 5/16" I.D. SIZE 5
20-086	NOZZLE CARBIDE, 3/8" I.D. SIZE 6
20-053	"O"RING – NOZZLE SEALING
20-040	GUN BODY ONLY
20-052	LOCKNUT, ORIFICE
20-063	RUBBER COVER, ORIFICE
20-064	ORIFICE AIR 4/32" I.D. SIZE 4 INCLD. #6 & #7
20-065	ORIFICE AIR 5/32" I.D. SIZE 5 INCLD. #6 & #7
20-066	ORIFICE AIR 6/32" I.D. SIZE 6 INCLD. #6 & #7
21-032	CLAMP, HOSE
18-084	HOSE, MEDIA ½" I.D. (SPECIFY LENGTH)
14-302	FITTING-HOSE TO GUN ½" HOSE x 3/8" MPT
20-041	GUN, STD. COMP. W/CERAMIC NOZZLE (SPECIFY LENGTH)
20-042	GUN, STD. COMP. W/CARBIDE NOZZLE (SPECIFY LENGTH)
11-1524	DUST COLLECTOR CARTRIDGE (INCLUDES 2A, 2B, 2C)
13-200	MOTOR, 120V, 60/50 HZ, 6.9 AMP

Little Blaster™  
ELECTRICAL DIAGRAM

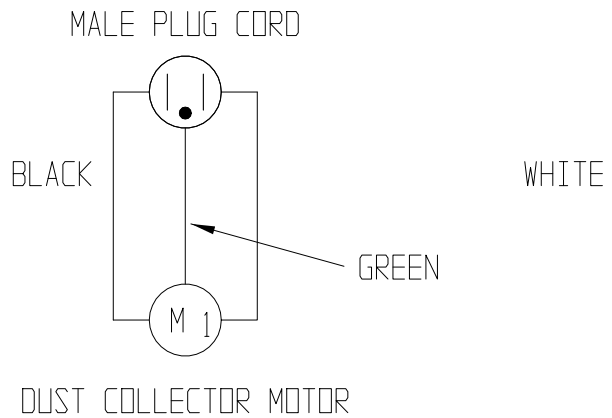
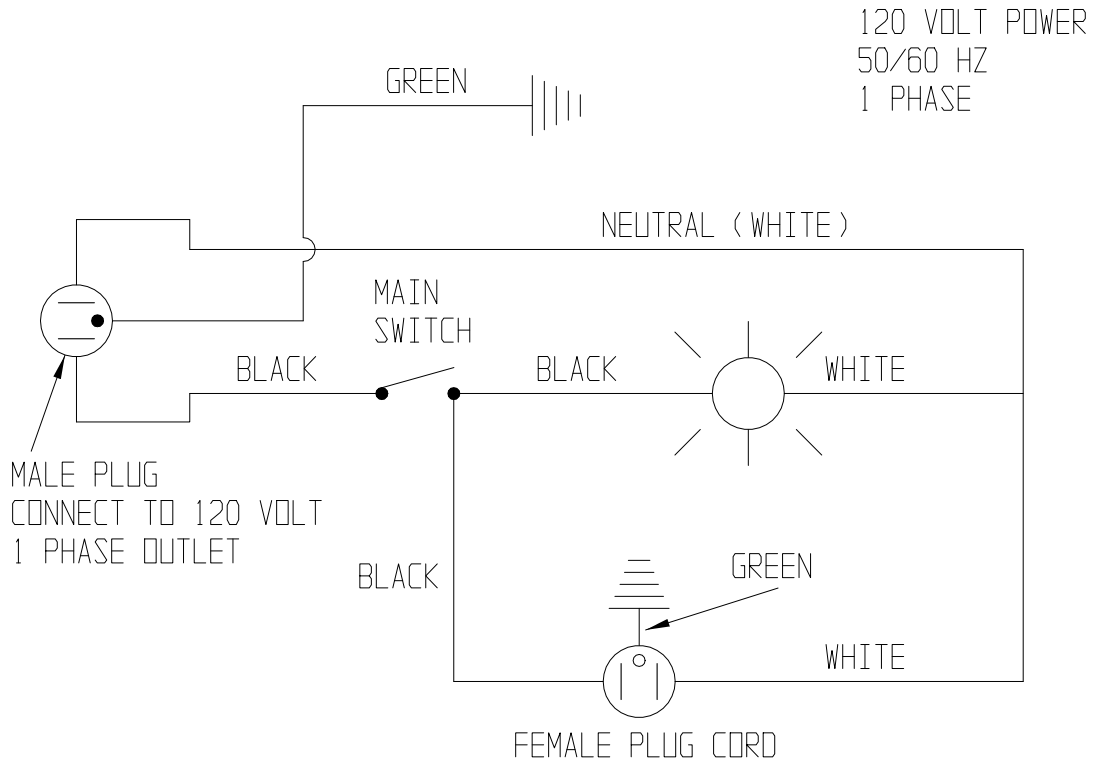

## WARRANTY

# BLAST-IT-ALL®

A Division of Hess Manufacturing, Inc.  
185 Piper Lane Salisbury, NC 28145  
P O Box 1615 Salisbury, NC 28147  
Toll Free 800-535-2612  
Fax 704-638-9311



Hess Manufacturing, Inc. Warrants to the original purchaser of the merchandise sold, to be free from defects in material or workmanship under normal use and service for a period of (5) years. **This warranty does not cover typical wear items.** Upon prompt notification by the purchaser, to Hess Manufacturing, Inc, components that are determined by Hess Manufacturing, Inc to be defective will be repaired or replaced at no additional charge F.O.B. our factory.

This warranty requires the following:

- 1) **A completed and returned Warranty Registration card.**
- 2) **Use of Genuine Blast-it-all® OEM replacement parts purchased through Hess Manufacturing, Inc, Blast-it-all® to include common wear items. For the entire period of the warranty.**
- 3) **Failures to provide proof of the purchase of Blast-it-all® OEM wear Items voids warranty.**

Manufacturer shall have the right to inspect prior replacing all merchandise in question.

Manufacturer shall not be required to pay any removal or installation charges whatsoever

Manufacturer shall not be held liable for prospective profits, special or consequential damages, nor shall any recovery of any kind against manufacturer be greater in amount the cost of the repairs of defects in workmanship

This warranty does not apply to damage caused by accidents, damage occurring during transit, alterations by unauthorized personnel, abuse or damage by flood, fire or acts of God, nor by artificially generated electric currents or any other cause whatsoever except defects in material or factory workmanship.

In ALL cases, defective parts must be returned to Hess Manufacturing, Inc, before credit is issued.

This warranty is in lieu of all other warranties expressed, written or implied and releases Hess Manufacturing, Inc of all other obligations and liabilities whatsoever. This warranty neither assumes nor authorizes any person any obligation other than those specified by this warranty.



**DO NOT USE SAND! SAND WILL CAUSE SILICA DUST, WHICH IS THE CAUSE OF SILICOSIS DISEASE, A CONDITION OF MASSIVE FIBROSIS OF THE LUNGS. THIS STATEMENT INDICATES POTENTIAL PERSONEL HAZARD. FAILURE TO COMPLY WITH THESE INSTRUCTIONS MAY RESULT IN PERSONAL INJURY.**

## VENTURI BLAST DATA

<b>VENTURI GUN AIR * MOTOR DATA:</b>								
<b>NOZZLE: INCHES:</b>	<b>ORIFICE: INCHES:</b>	<b>BLAST PRESSURE (PSI):</b>						<b>REQUIREMENTS:</b>
		<b>50</b>	<b>60</b>	<b>70</b>	<b>80</b>	<b>90</b>	<b>100</b>	
<b>#4 1/4"</b>	<b>#4 4/32"</b>	14.26	16.39	18.62	20.76	22.99	25.00	AIR (CFM)
		<b>5</b>	<b>5</b>	<b>5</b>	<b>7.5</b>	<b>7.5</b>	<b>7.5</b>	<b>MOTOR (HP)</b>
<b>#5 5/16"</b>	<b>#5 5/32"</b>	22.28	25.61	29.09	32.43	35.92	40.00	AIR (CFM)
		<b>7.5</b>	<b>7.5</b>	<b>7.5</b>	<b>10</b>	<b>10</b>	<b>10</b>	<b>MOTOR (HP)</b>
<b>#6 3/8"</b>	<b>#6 3/16"</b>	32.01	36.86	41.90	46.85	51.60	56.00	AIR (CFM)
		<b>10</b>	<b>10</b>	<b>15</b>	<b>15</b>	<b>15</b>	<b>15</b>	<b>MOTOR (HP)</b>

<b>VENTURI GUN NOZZLE PART #'S:</b>			
<b>NOZZLES: INCHES:</b>	<b>#4 1/4</b>	<b>#5 5/16</b>	<b>#6 3/8</b>
CERAMIC	20-074	20-075	20-076
<b>TUNGSTEN</b>	<b>20-084</b>	<b>20-085</b>	<b>20-086</b>
BORON	20-094	20-095	20-096

<b>VENTURI GUN ORIFICE PART #'S:</b>			
<b>ORIFICE: INCHES:</b>	<b>#4 4/32</b>	<b>#5 5/32</b>	<b>#6 6/32</b>
BRASS	20-064	20-065	20-066

# INDEX

---

## A

ABRASIVE · 10, 14  
AIR · 9, 14, 17, 18

---

## B

BLAST · 1, 4, 9, 10, 11, 12, 14, 15,  
16, 17, 18, 19, 21, 30  
BLAST DATA · 30

---

## C

CAKING · 17  
CARBIDE · 27  
CARTRIDGE · 9, 10, 15, 16, 17, 19,  
26, 27  
CERAMIC · 27  
CLOG · 14, 17

---

## D

DAMAGE · 9, 18, 19  
DISTRIBUTOR · 14  
DOOR · 4  
DUST · 1, 3, 9, 15, 16, 17, 19, 26, 27

---

## E

ELECTRICAL · 9, 10, 28  
EXPLOSION · 3, 4, 14  
EYE PROTECTION · 3

---

## F

FIBROSIS · 3  
FINISH · 14  
FUZE · 10

---

## G

GASKET · 9, 15, 26  
GLOVE · 27  
GRATE · 12  
GREASE · 14  
GROMMET · 12  
GROUNDED · 3, 10  
GUN · 4, 11, 12, 14, 17, 18, 19, 20,  
21, 27

---

## H

HEARING · 3  
HOSE · 9, 11, 12, 17, 18, 19, 20, 27

---

## L

LIGHT · 9, 10, 24

---

## M

MAINTENANCE · 17, 18  
MEDIA · 10, 12, 14, 17, 18, 19, 27  
MEDIA VALVE · 13, 27  
MOISTURE · 9, 14, 17  
MOTOR · 15, 16, 26, 27  
MYLAR · 9, 19, 27

---

## N

NOZZLE · 16, 17, 18, 27

---

## O

OIL · 9, 14, 17  
OPERATION · 4, 9, 14, 15, 16

ORIFICE · 18, 20, 27  
OSHA · 3, 5, 6, 7, 8

---

## P

PARTS · 4, 14, 17, 19, 20, 21, 23, 24,  
25, 26, 27  
PLUG · 9, 26  
PROTECTOR · 27  
PSI · 14, 16, 17, 18

---

## Q

QUICK DISCONNECT · 10

---

## S

SAFETY · 3, 4  
SAND · 3  
SCREEN · 17  
SEPARATOR · 9  
SILICOSIS · 3  
SUMP · 12, 16, 17, 19  
SWITCH · 16

---

## V

VENTILATION · 3

---

## W

WATER · 9, 17  
WINDOW · 9, 14, 19, 27